

Die#: V-014  
Size: 3.2165" x 6.2341"  
Gap: .25"  
Corner Radius: .015625"  
Material: Matte WS  
Liner: 44pk

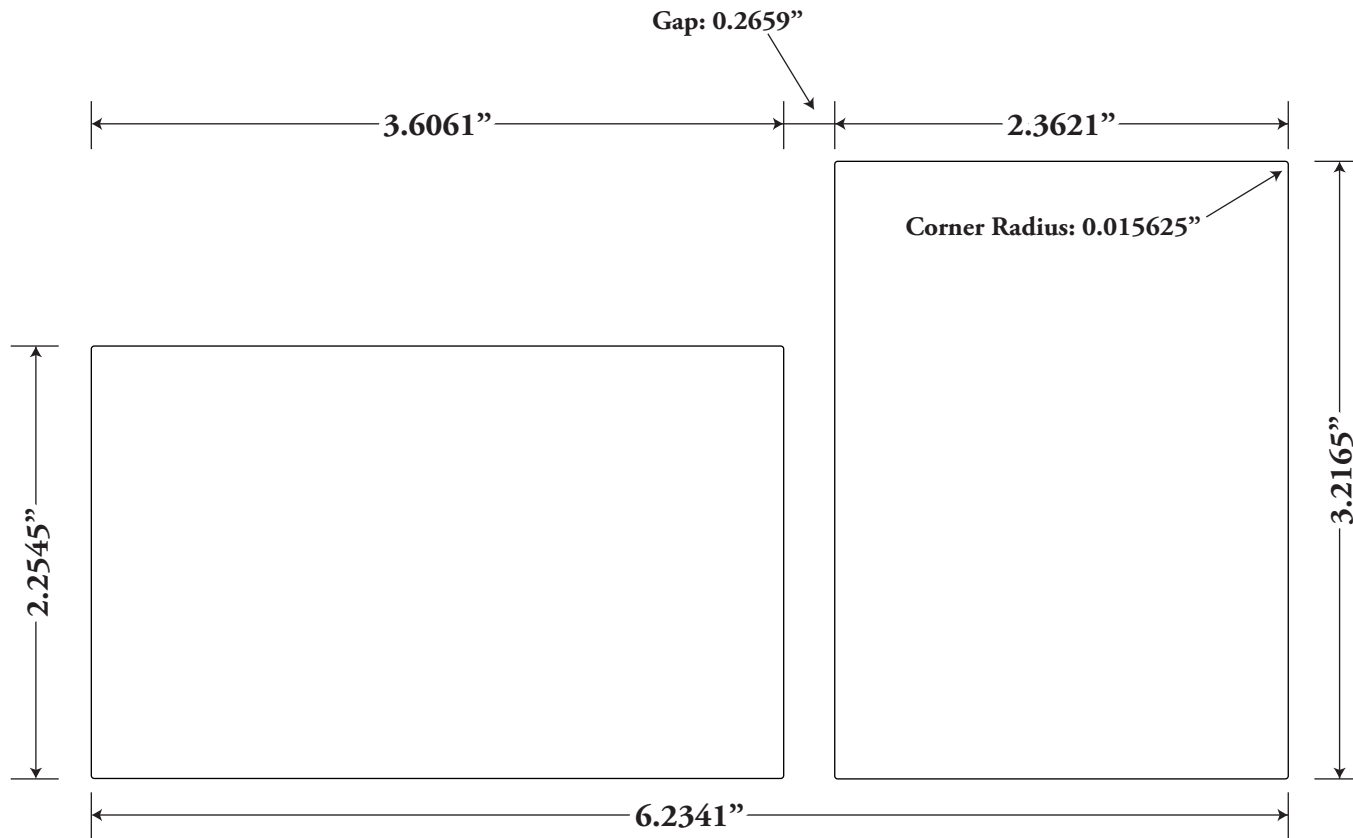

← Run Direction →

Die#: V-049  
Size: 4" x 8.125"  
Corners: 1/64"  
Material Type: CLASSIC CREST  
Varnish: GLOSS  
Laminate: NONE  
Special tooling: NONE

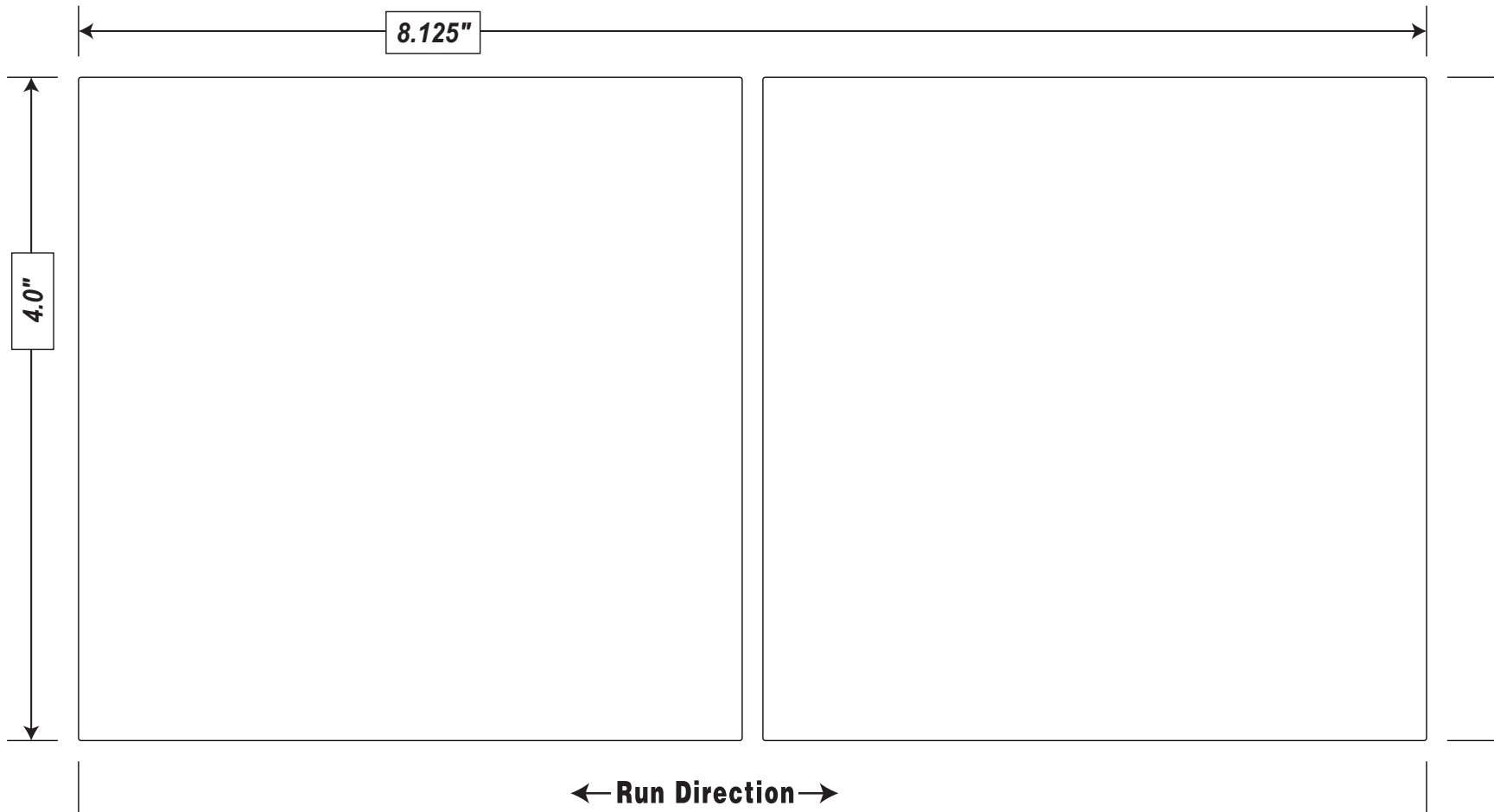

Die#: V-055  
Size: 2.75" x 7.5"  
Gap: .125"  
Corner Radius: .015625"  
Material: Gloss  
Liner: 44pk

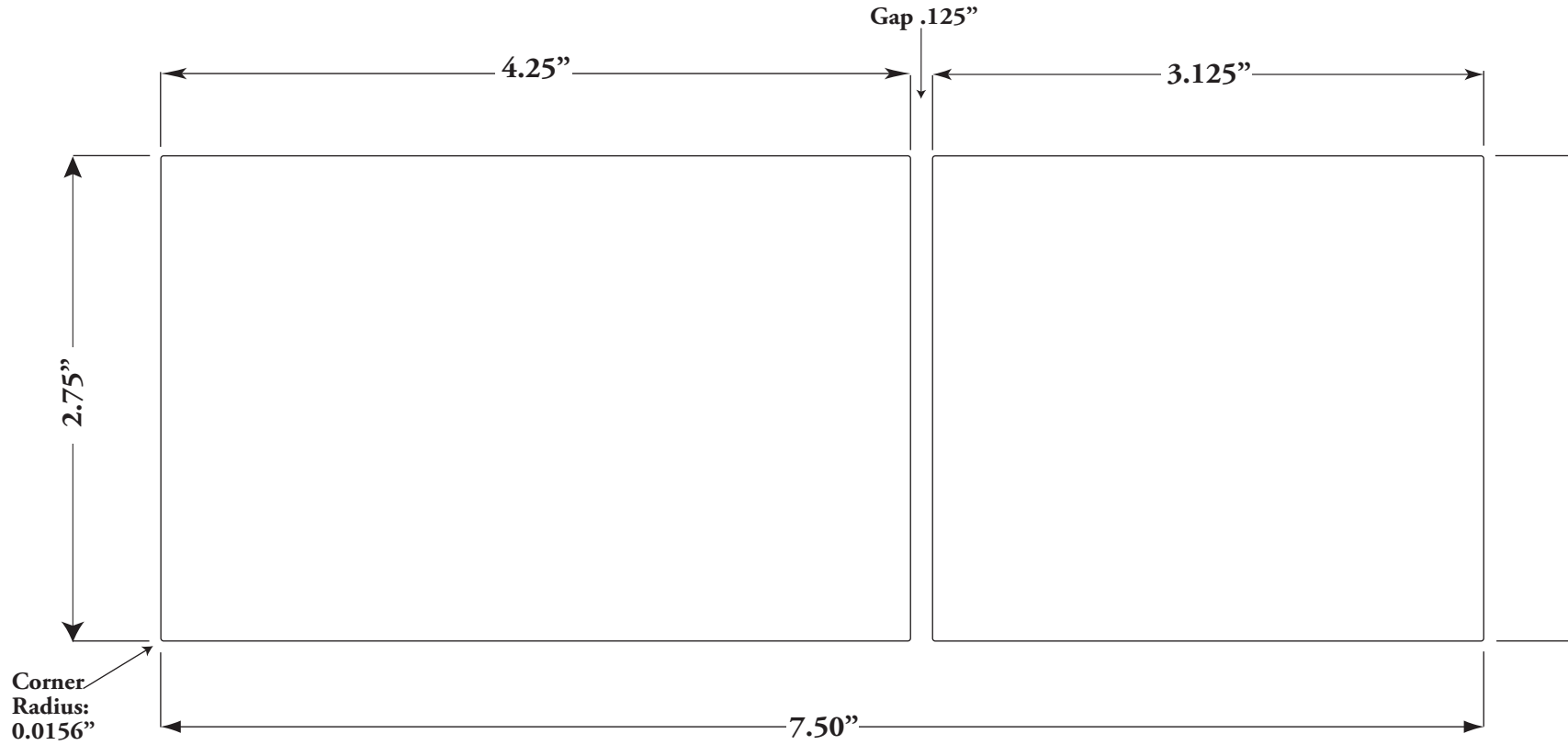

← Run Direction →

Die#: V-074  
Size: 3.125" x 8.375"  
Gap: .125"  
Corner Radius: .015625"  
Material: Classic Crest  
Liner: 44pk

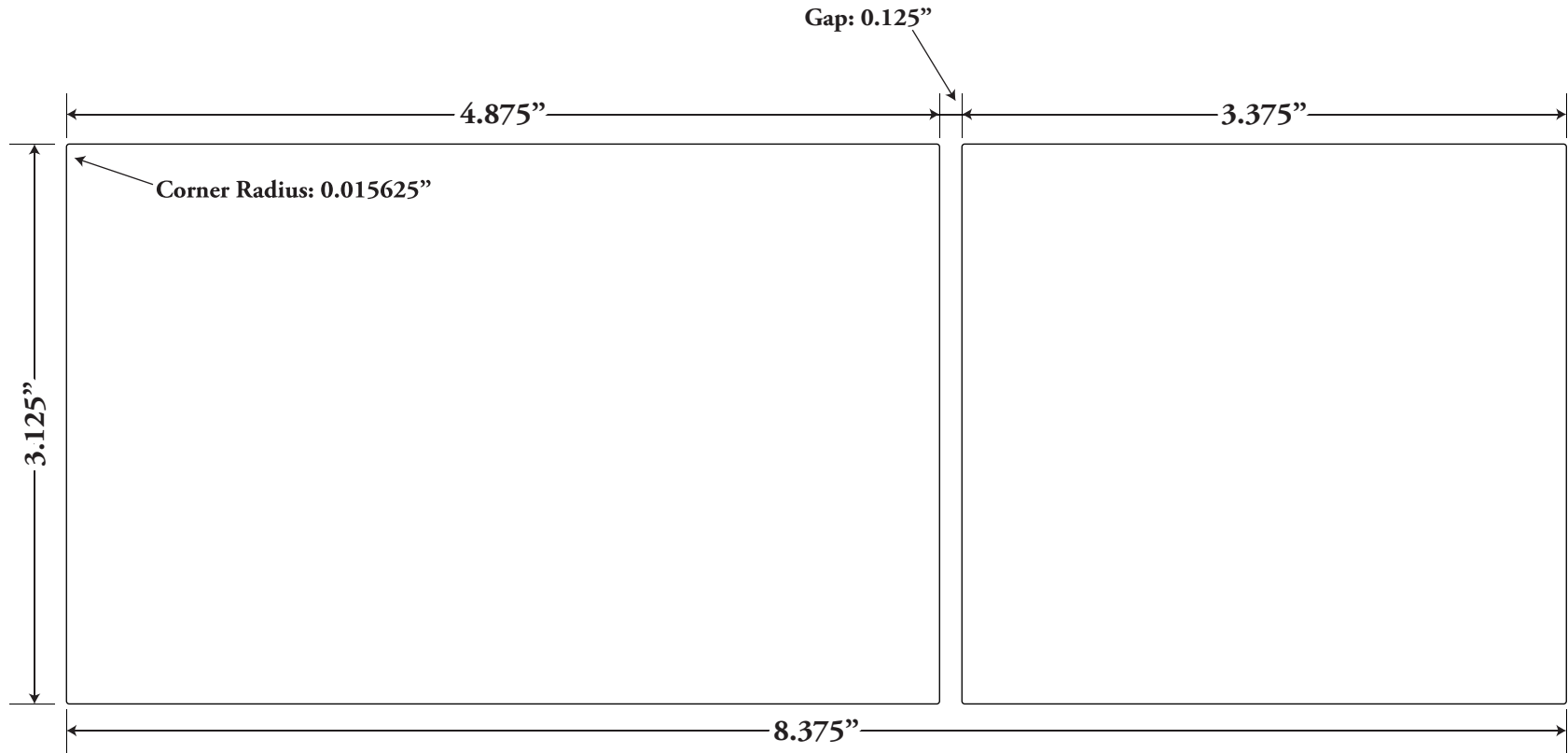

← Run Direction →

Die#: V-081  
Size: 2.7" x 7.7175"  
Gap: .1575"  
Corner Radius: .015625"  
Material: Estate 8  
Liner: 44pk

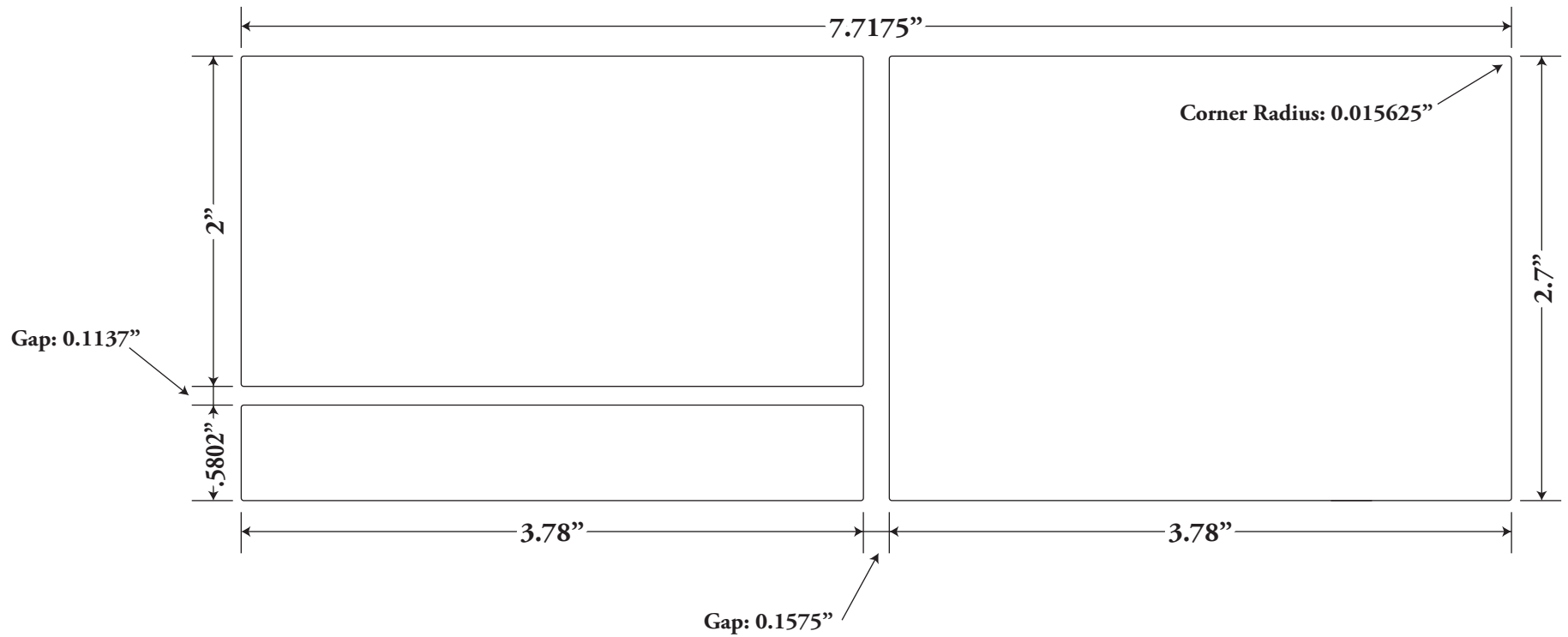

← Run Direction →

Die#: V-100  
Size: 3.5" x 6.125"  
Gap: .125"  
Corner Radius: .015625"  
Material: Gloss  
Liner: 44pk

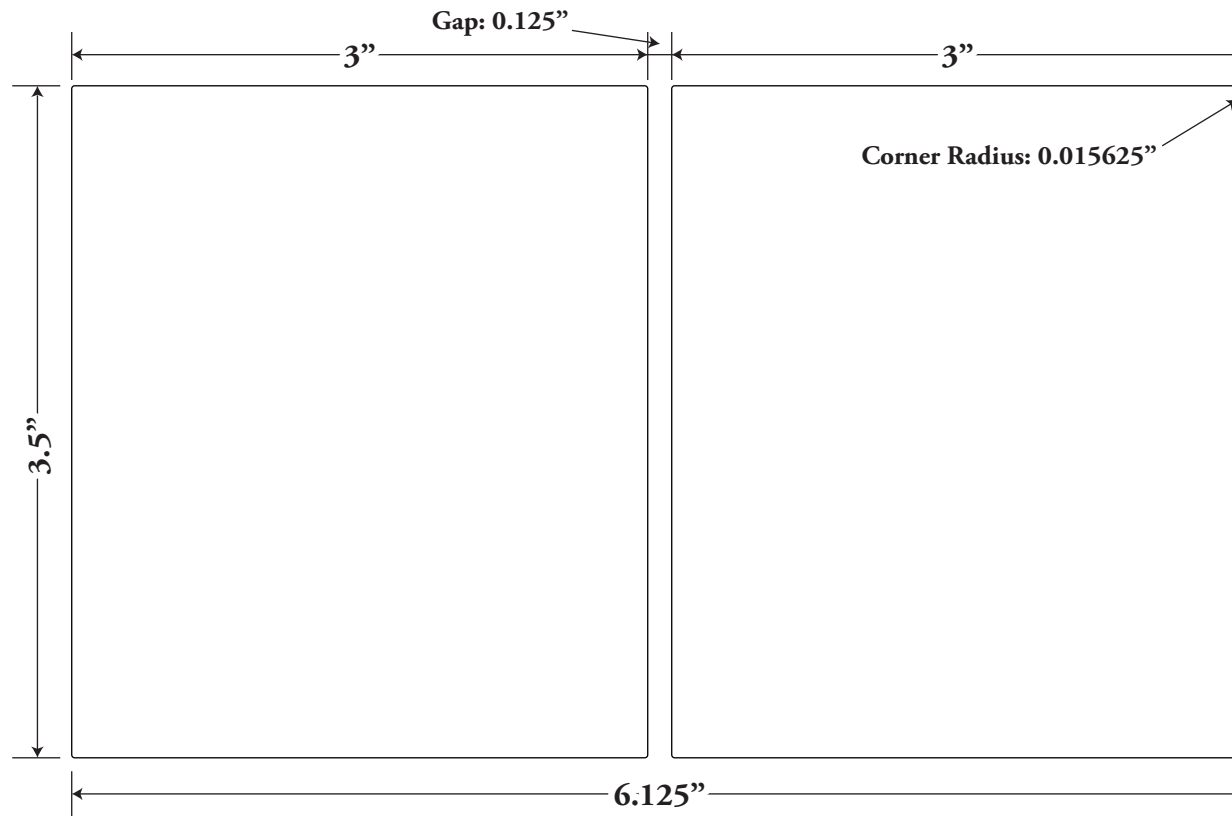

← Run Direction →

Die#: V-104  
Size: 3.0" x 6.875"  
Gap: .125"  
Corner Radius: .0156"  
Material: Classic Felt  
Liner: 44pk

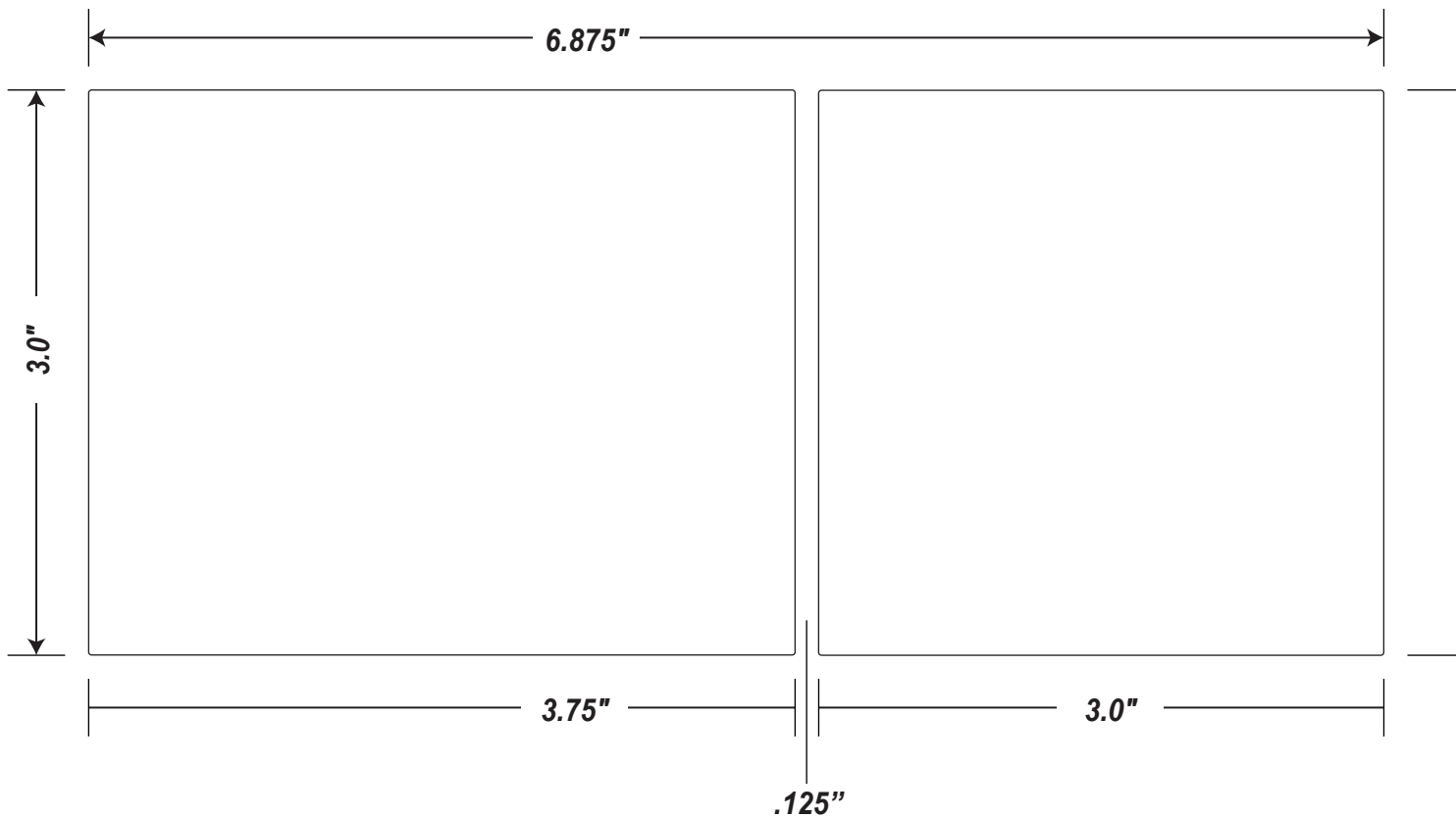

← Run Direction →

Die#: V-113  
Size: 3.5" x 7.125"  
Gap: .125"  
Corner Radius: .015625"  
Material: Matte Litho  
Liner: 44pk

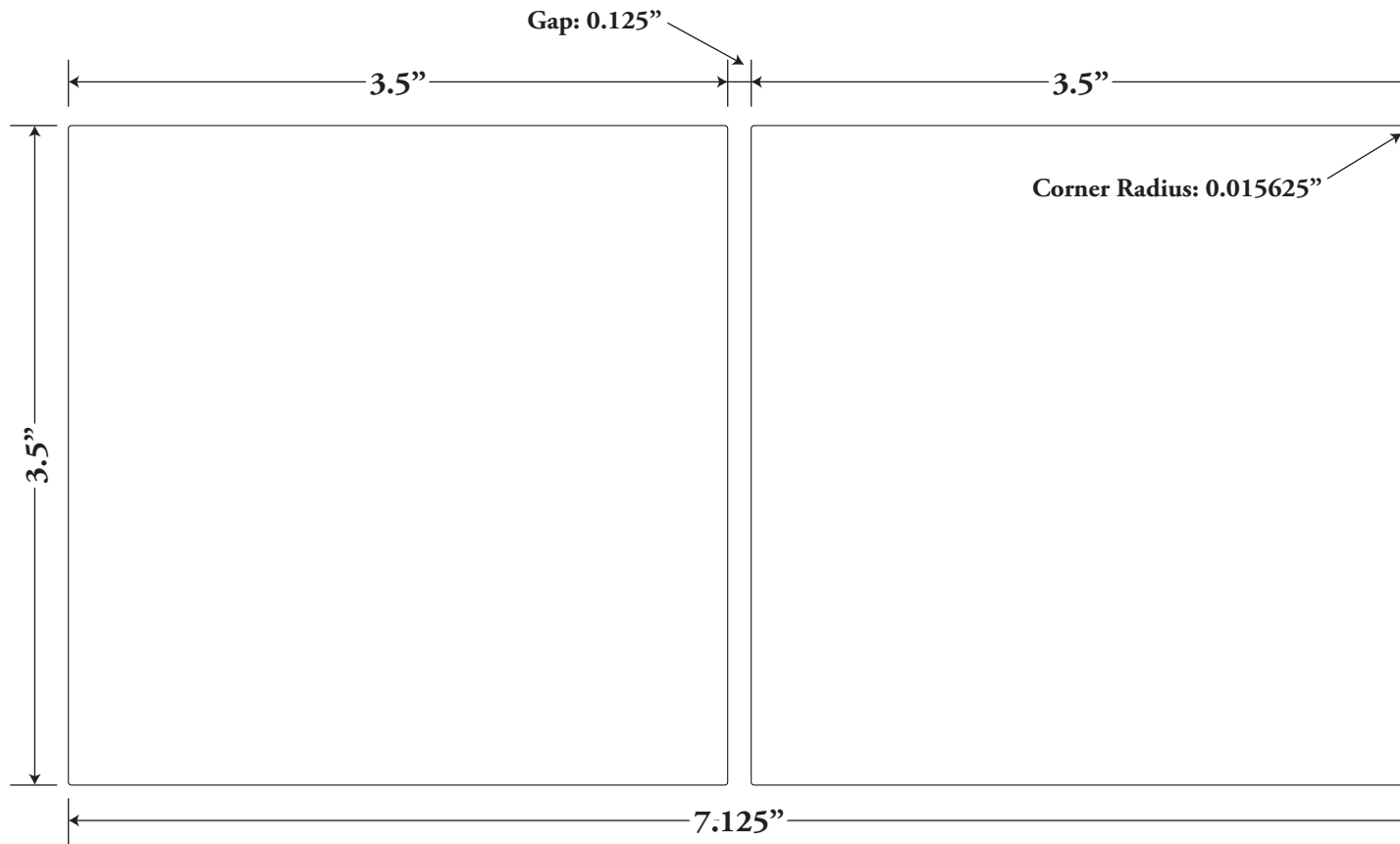

← Run Direction →

Die#: V-115  
Size: 4.891" x 5.916"  
Gap: .125"  
Corner Radius: .015625"  
Material: Gloss  
Liner: 44pk

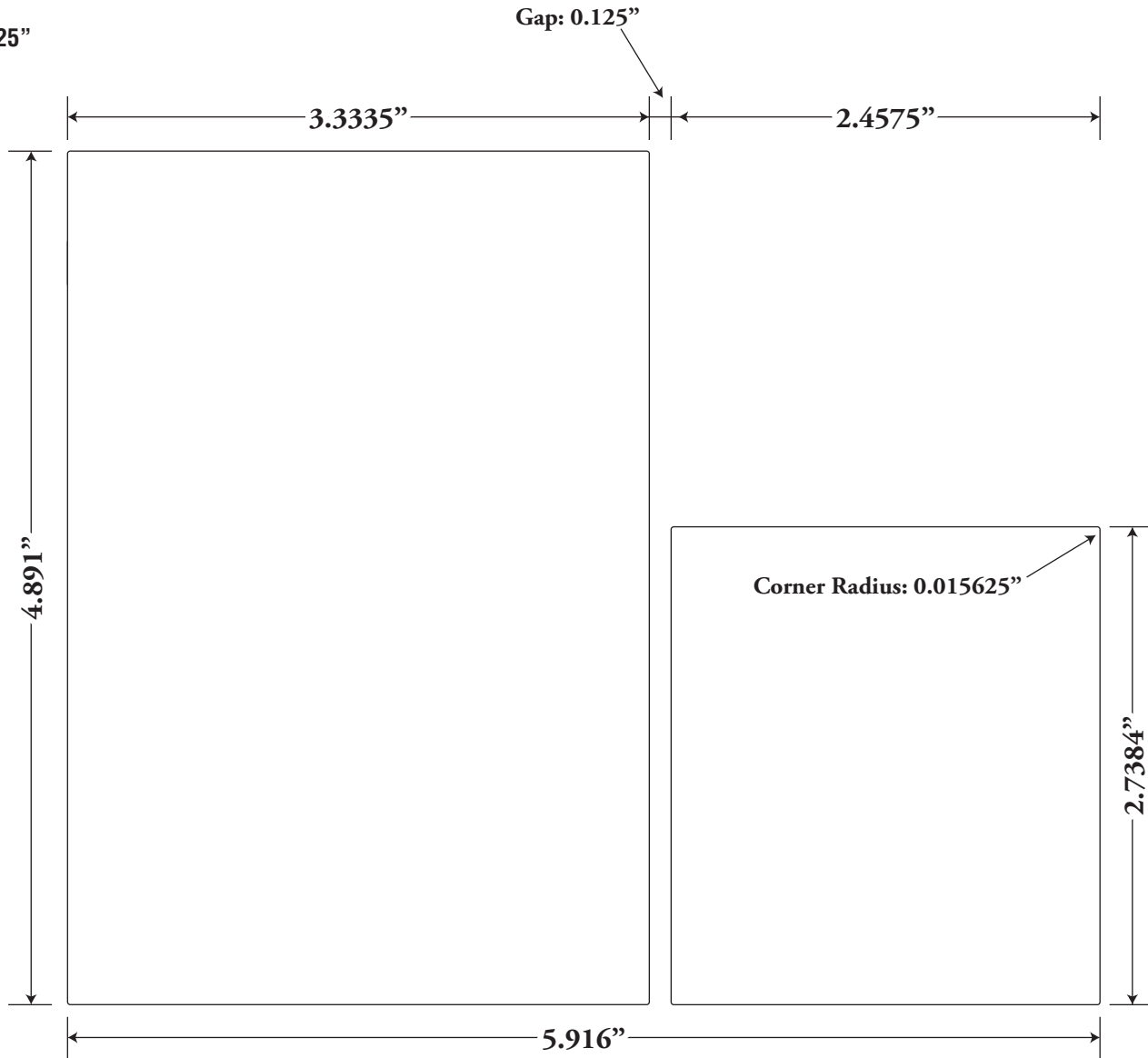

← Run Direction →

Die#: V-118  
Size: 2.875" x 5.875"  
Gap: .125"  
Corner Radius: .015625"  
Material: Primax  
Liner: 44pk

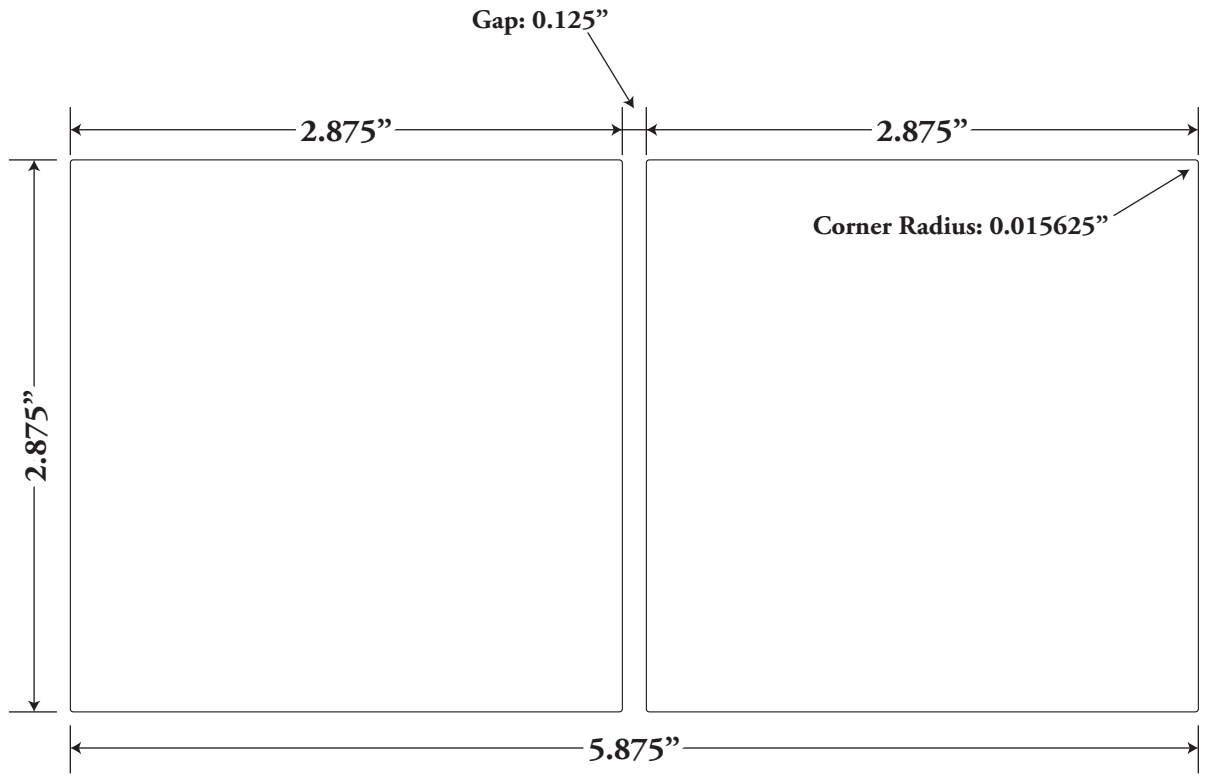

← Run Direction →

Die#: V-121  
Size: 4" x 5.625"  
Gap: .125"  
Corner Radius: .015625"  
Material: Matte  
Liner: 44pk

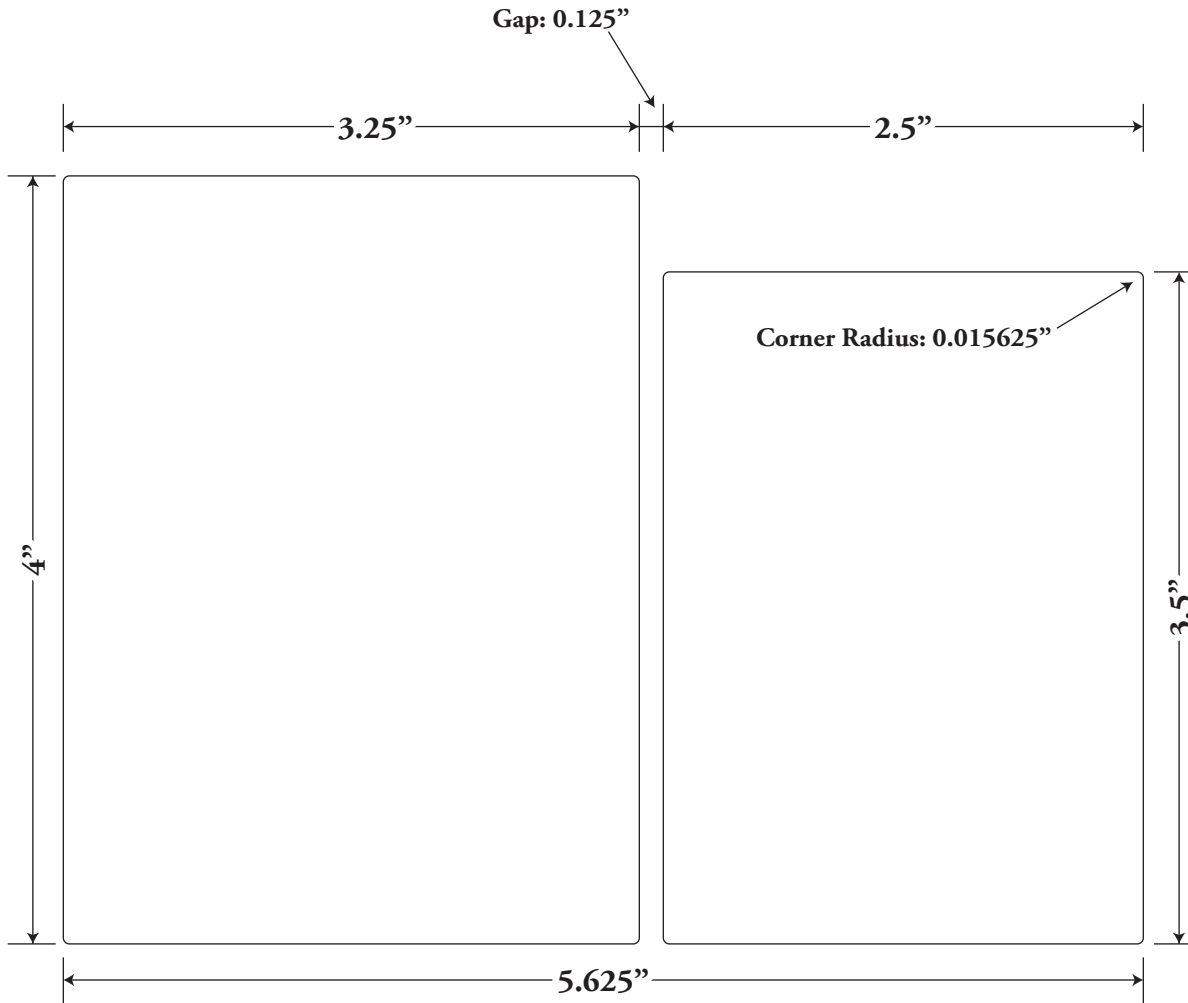

← Run Direction →

Die#: V-122  
Size: 3.625" x 6.375"  
Gap: .125"  
Corner Radius: .015625"  
Material: Classic Felt  
Liner: 44pk

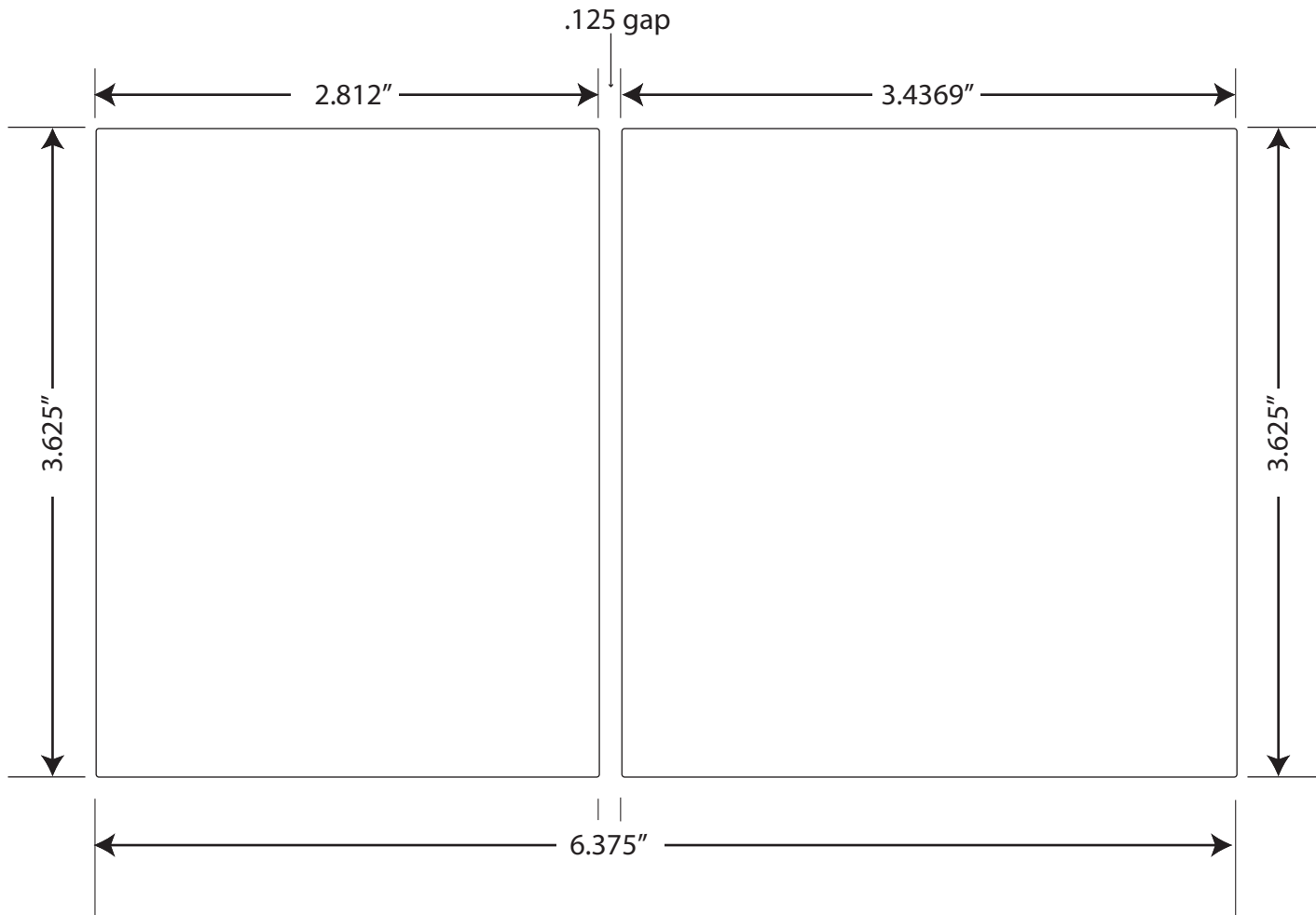

← Run Direction →

Die#: V-124  
Size: 3.75" x 6.875"  
Gap: .125"  
Corner Radius: .015625"  
Material: Bright White Felt  
Liner: 44pk

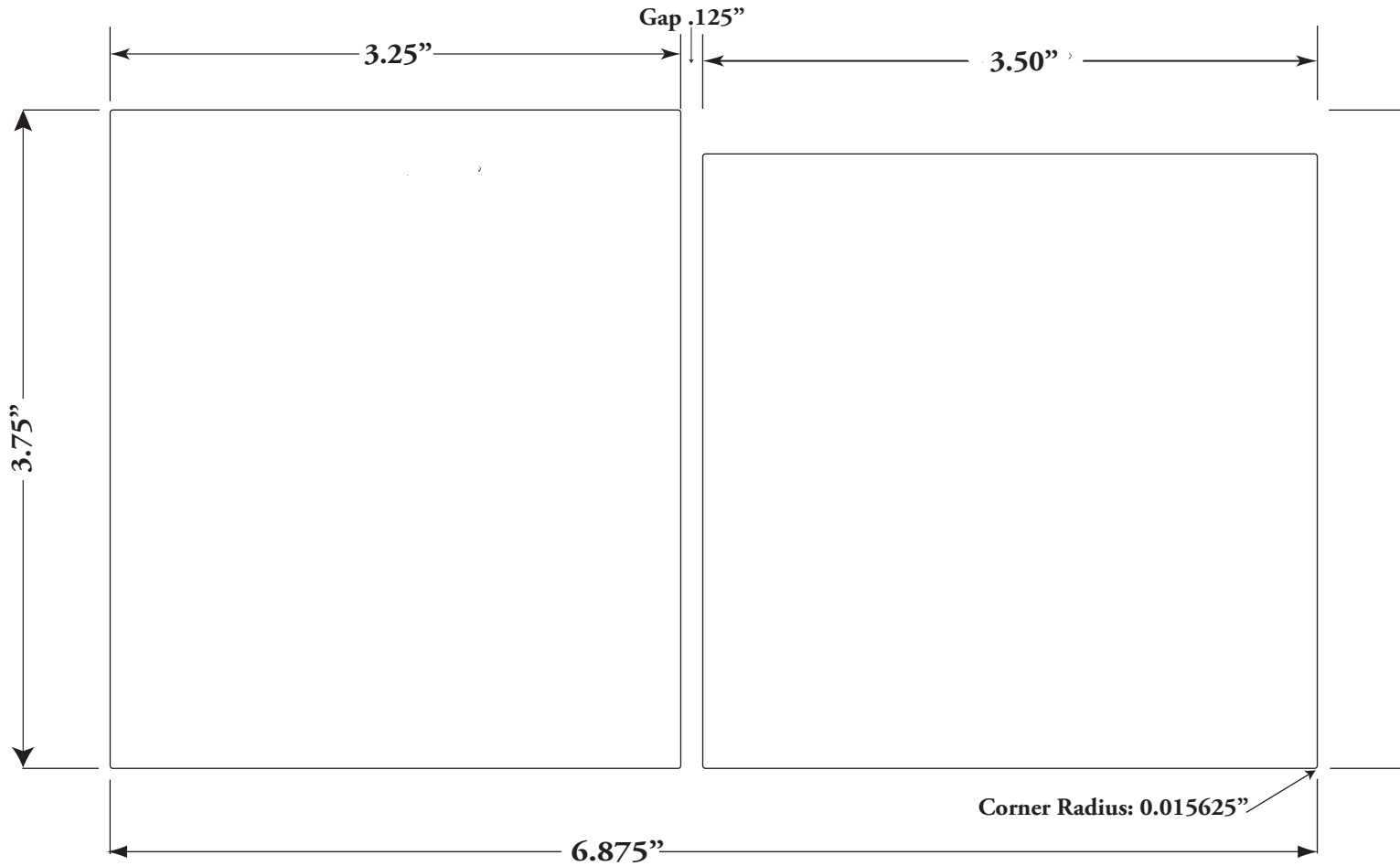

← Run Direction →

Die#: V-132  
Size: 3.75" x 6.5"  
Gap: .125"  
Corner Radius: .015625"  
Material: Classic Felt  
Liner: 44pk

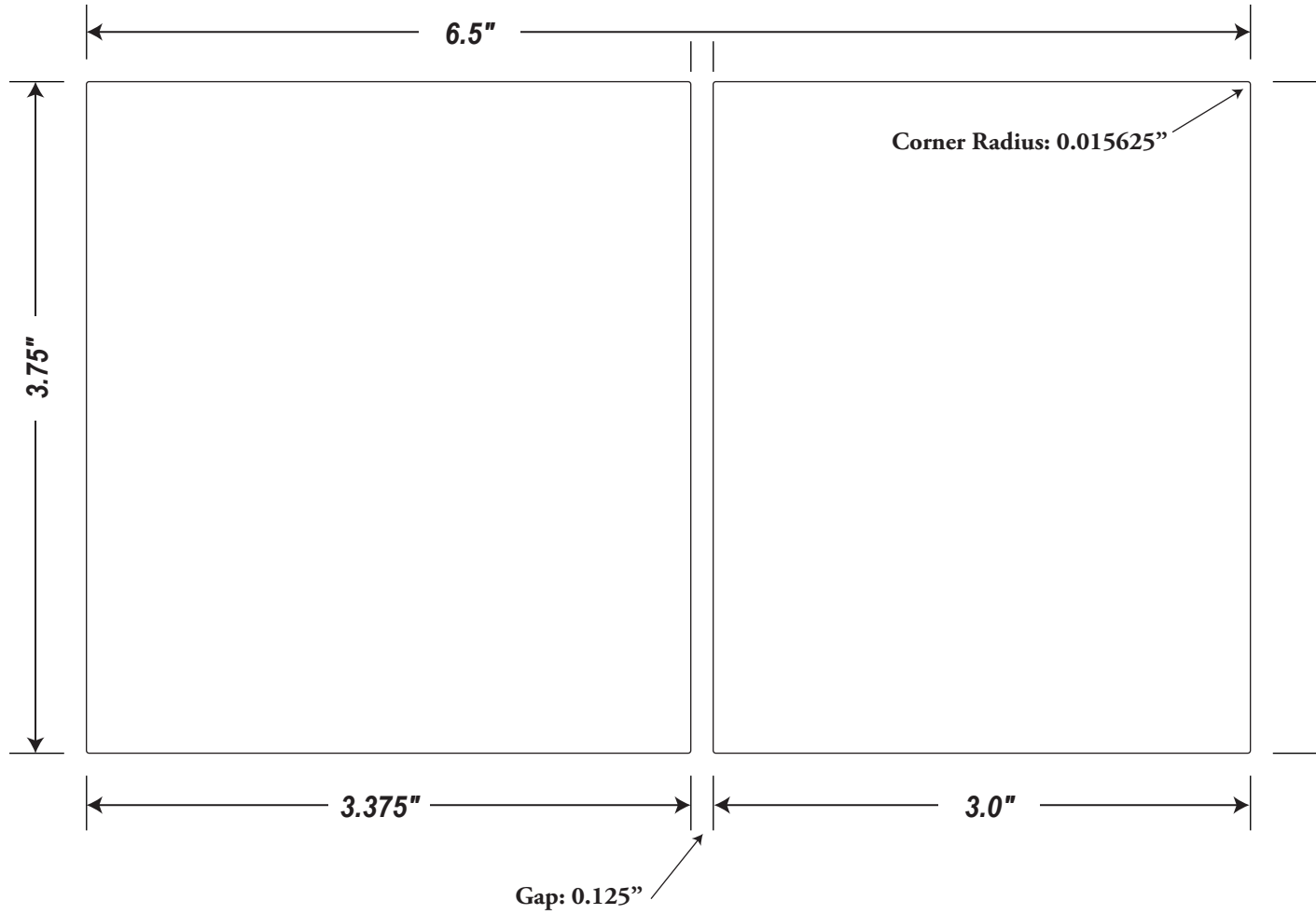

← Run Direction →

Die#: V-133  
Size: 3.25" X 8.375"  
Corners: 1/64"  
Material Type: Classic Felt  
Varnish: yes  
Laminate: no  
Special tooling: Bonham Foil Stamp

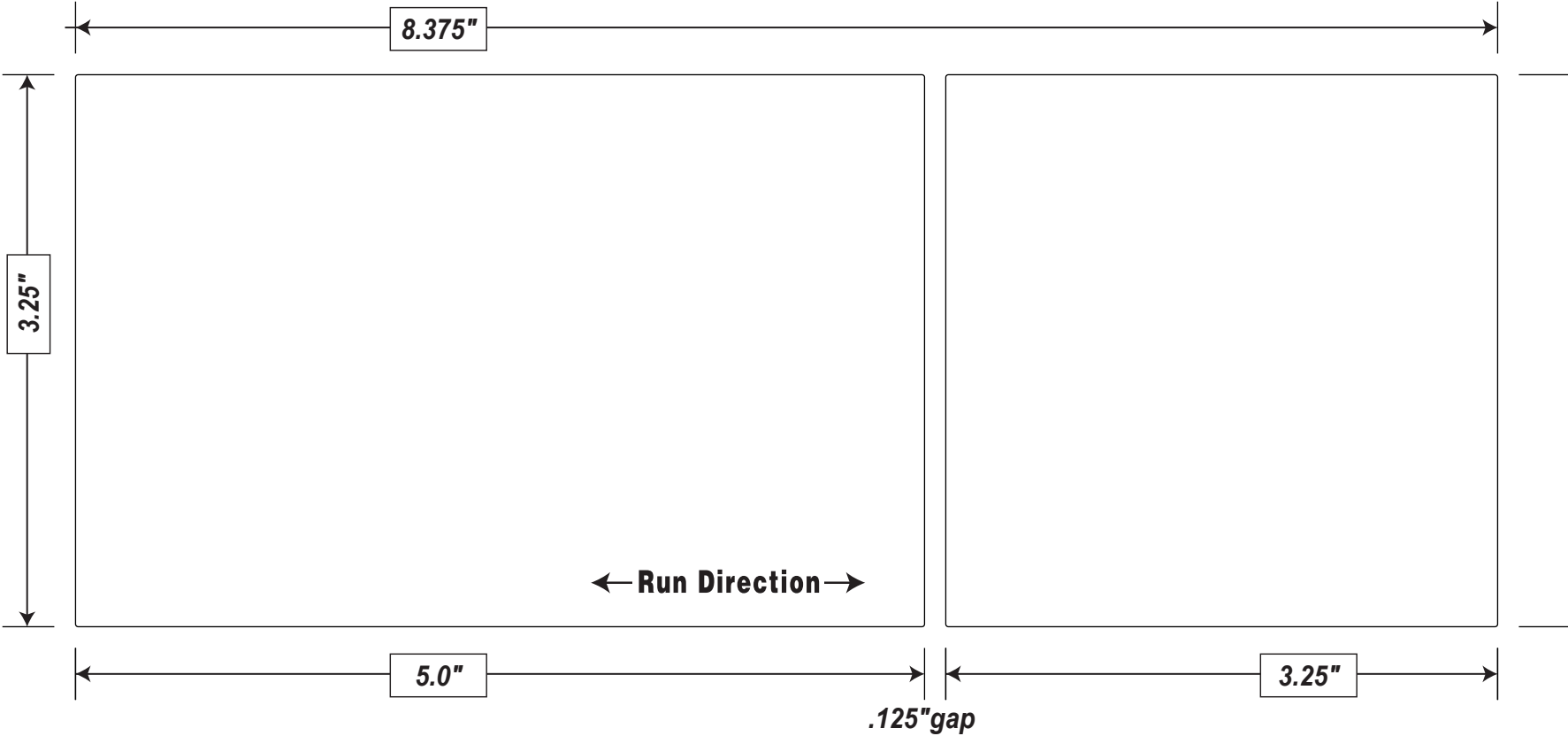

**Die#/Size:** V-142 4.8585" X 5.85"  
**Corners:** 1/64"  
**Material Type:** Classic Crest  
**Varnish:** Satin 2  
**Laminate:** None  
**Shape:** Special

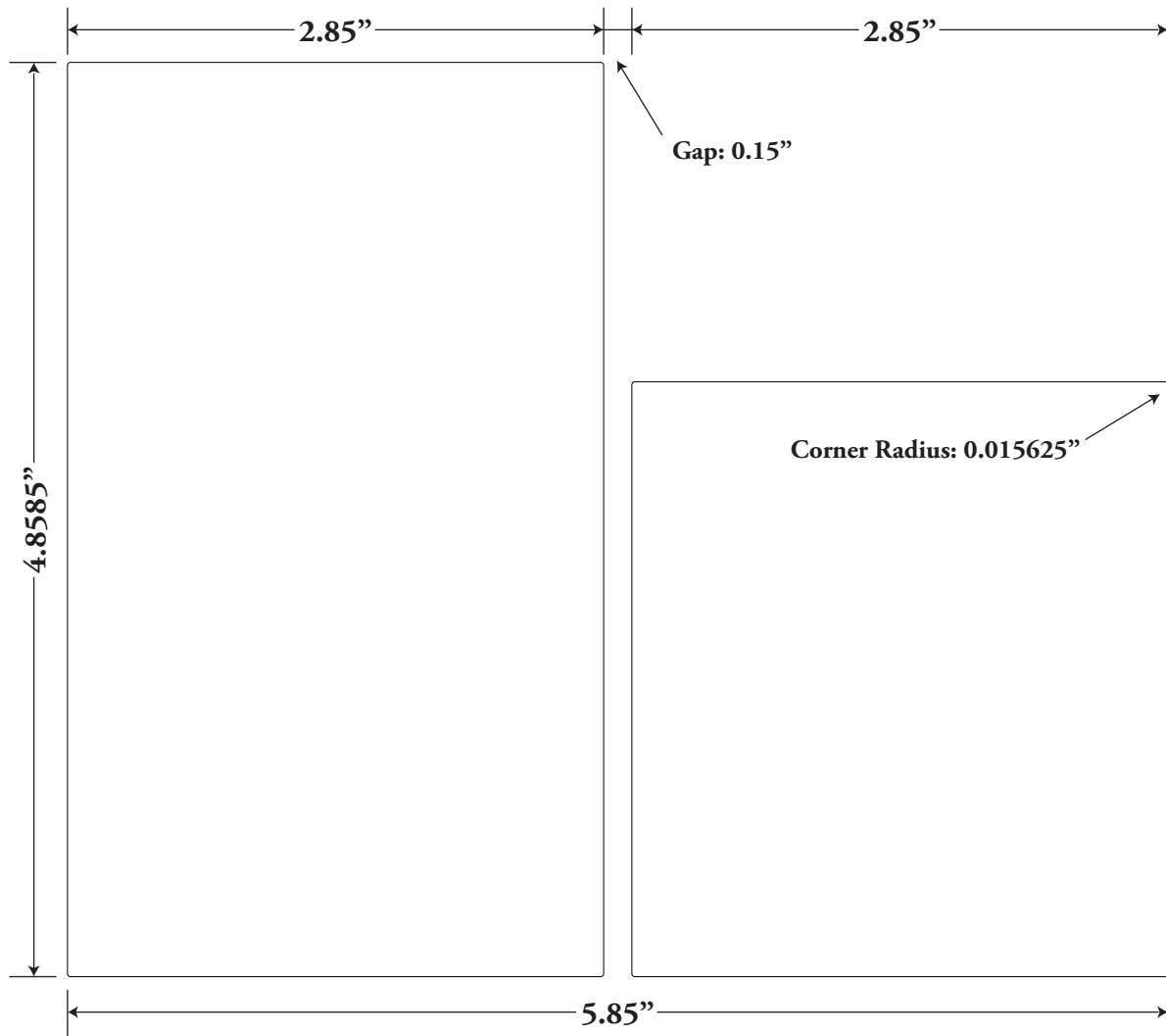

← Run Direction →

Die#: NEW  
Size: 4.25" x 6.25"  
Corners: .015"  
Material Type: sw matte

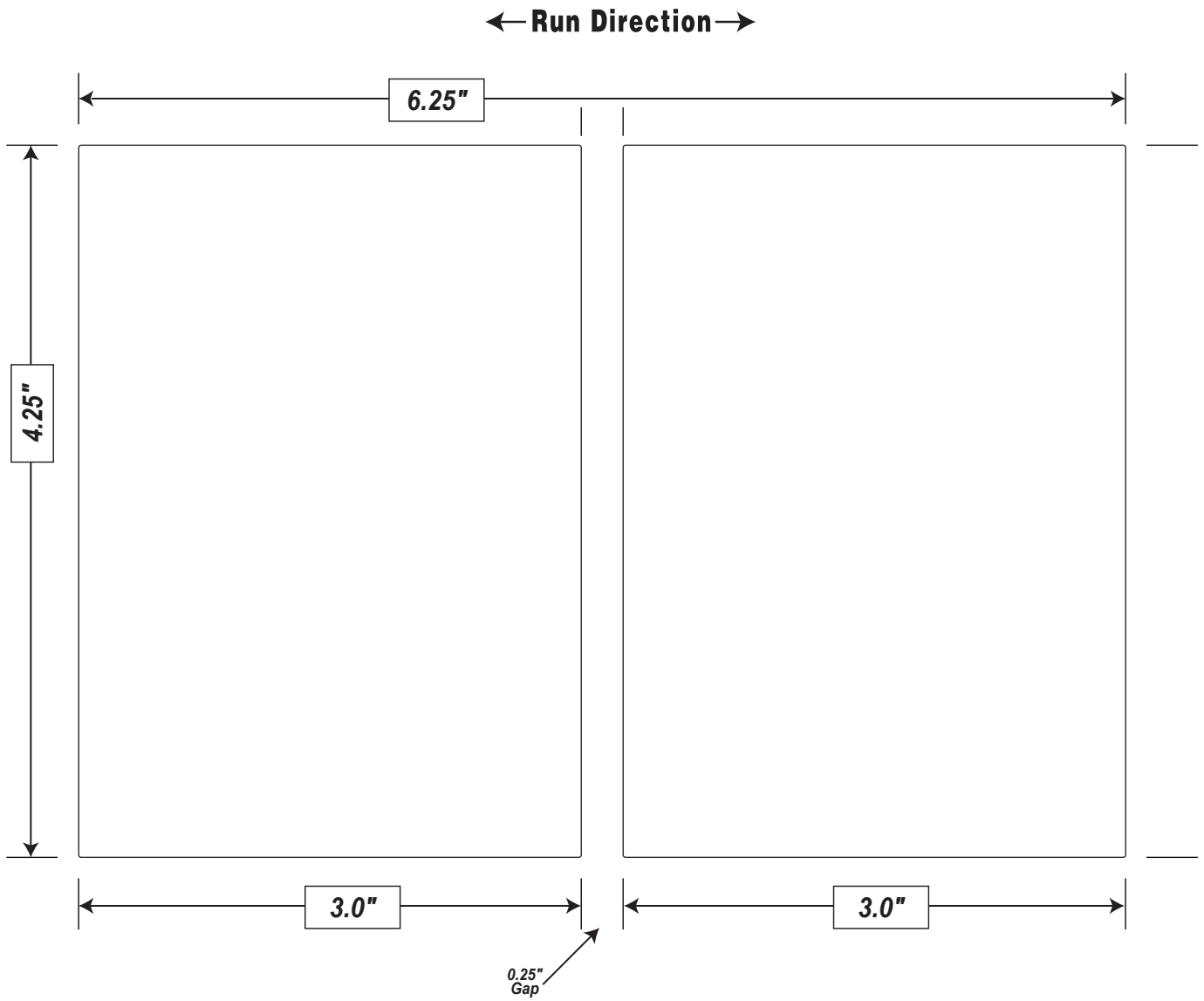

**Die#/Size:** V-154 3.4399" X 7.4863"  
**Corners:** 1/64"  
**Material Type:** Classic Felt  
**Varnish:** Satin Coat  
:

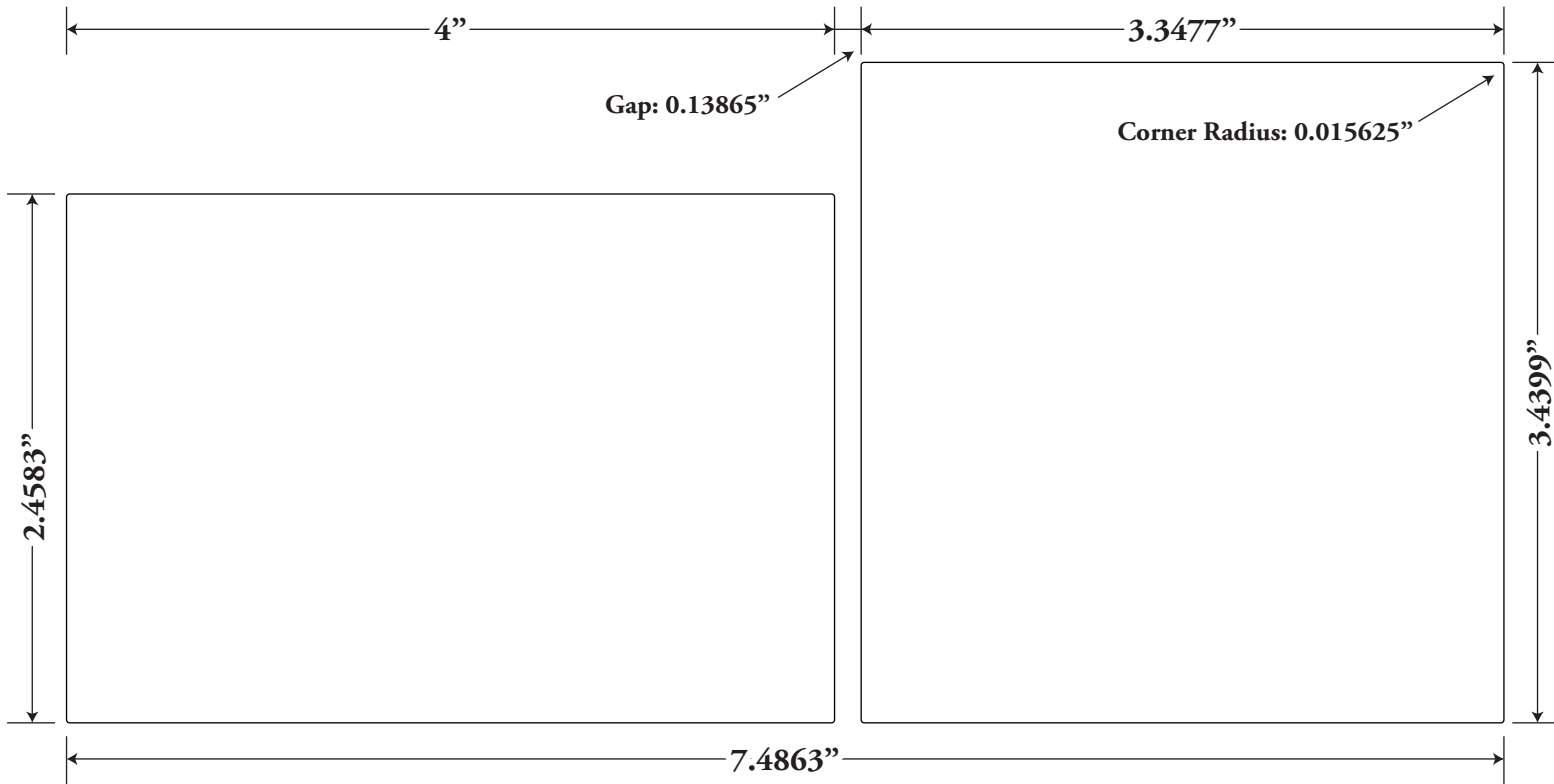

← Run Direction →

**Die#: V-155**  
**Size: 1.6231" x 8.7818"**  
**Corners: 1/64"**  
**Material Type: Classic Crest**  
**Varnish: Gloss Crystal Barrier**  
**Shape: Special**

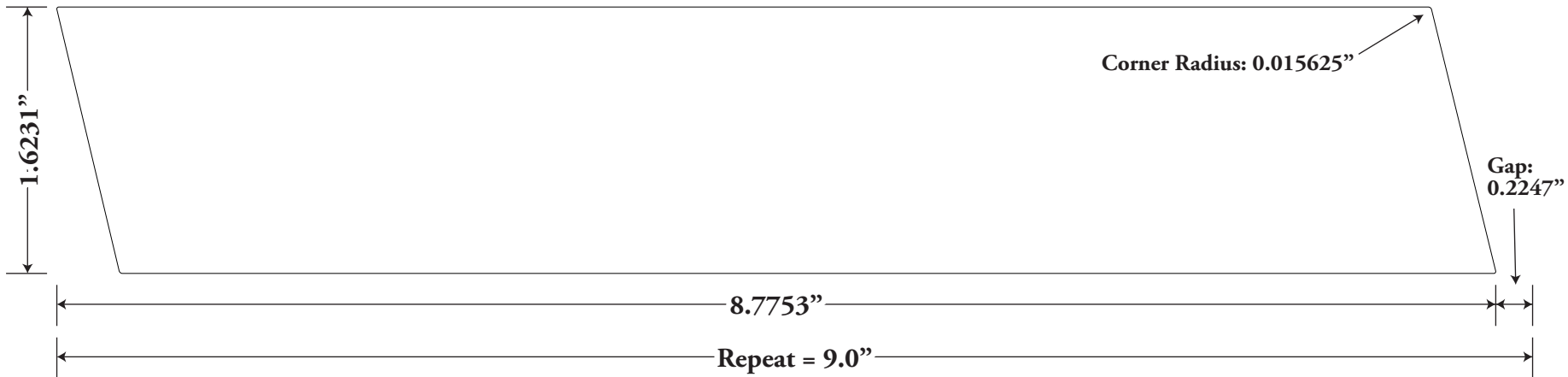

Die#: V-156  
Size: 3.652" x 7.375"  
Corners: .0156"  
Material Type: Matte Litho  
Varnish: Spot UV  
Laminate: none  
Special tooling: None

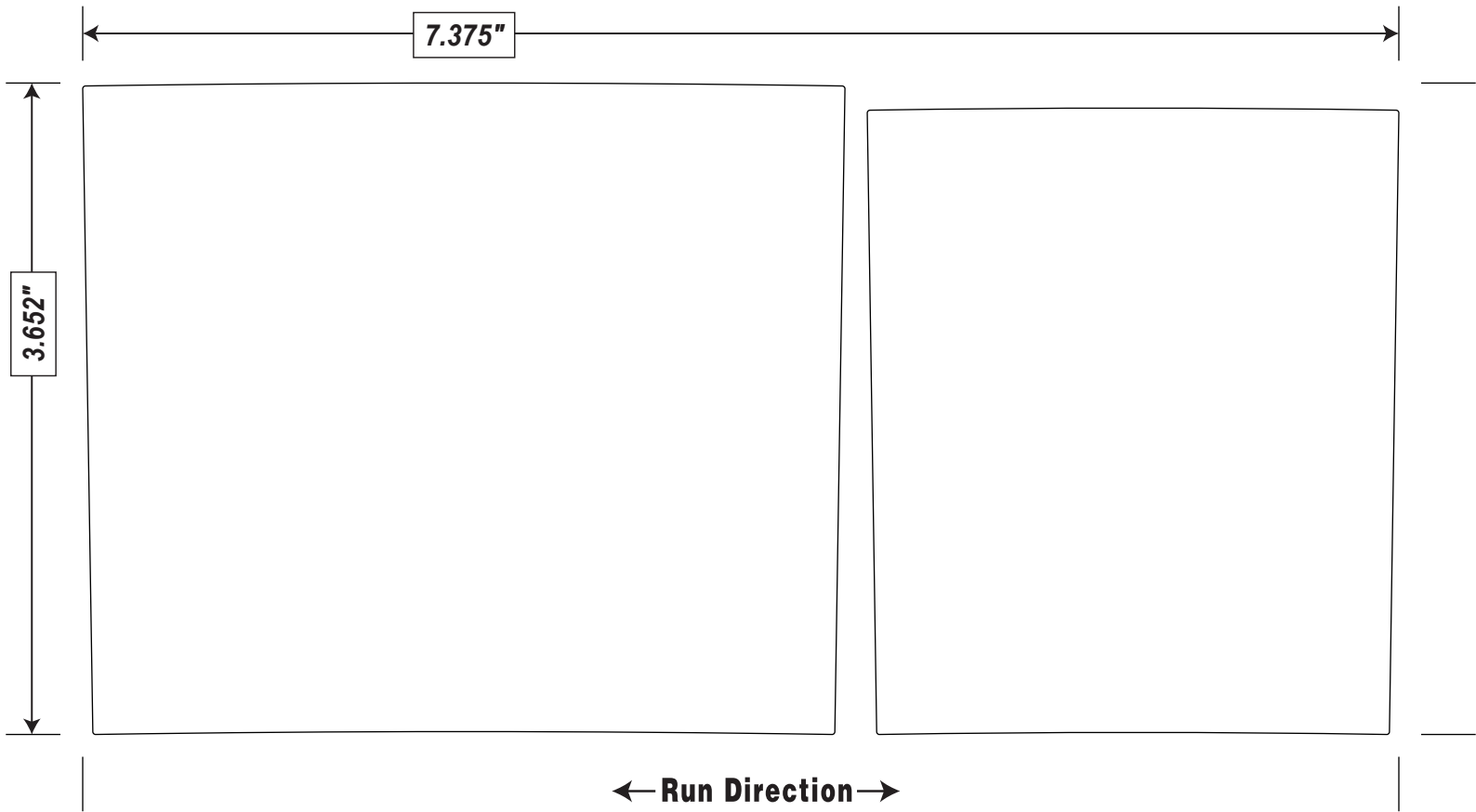

Die#: NEW  
Size: 3.7012" x 7.2056"  
Corners: Special  
Material Type: 2 ML White Bopp  
Varnish: Pearlescent UV

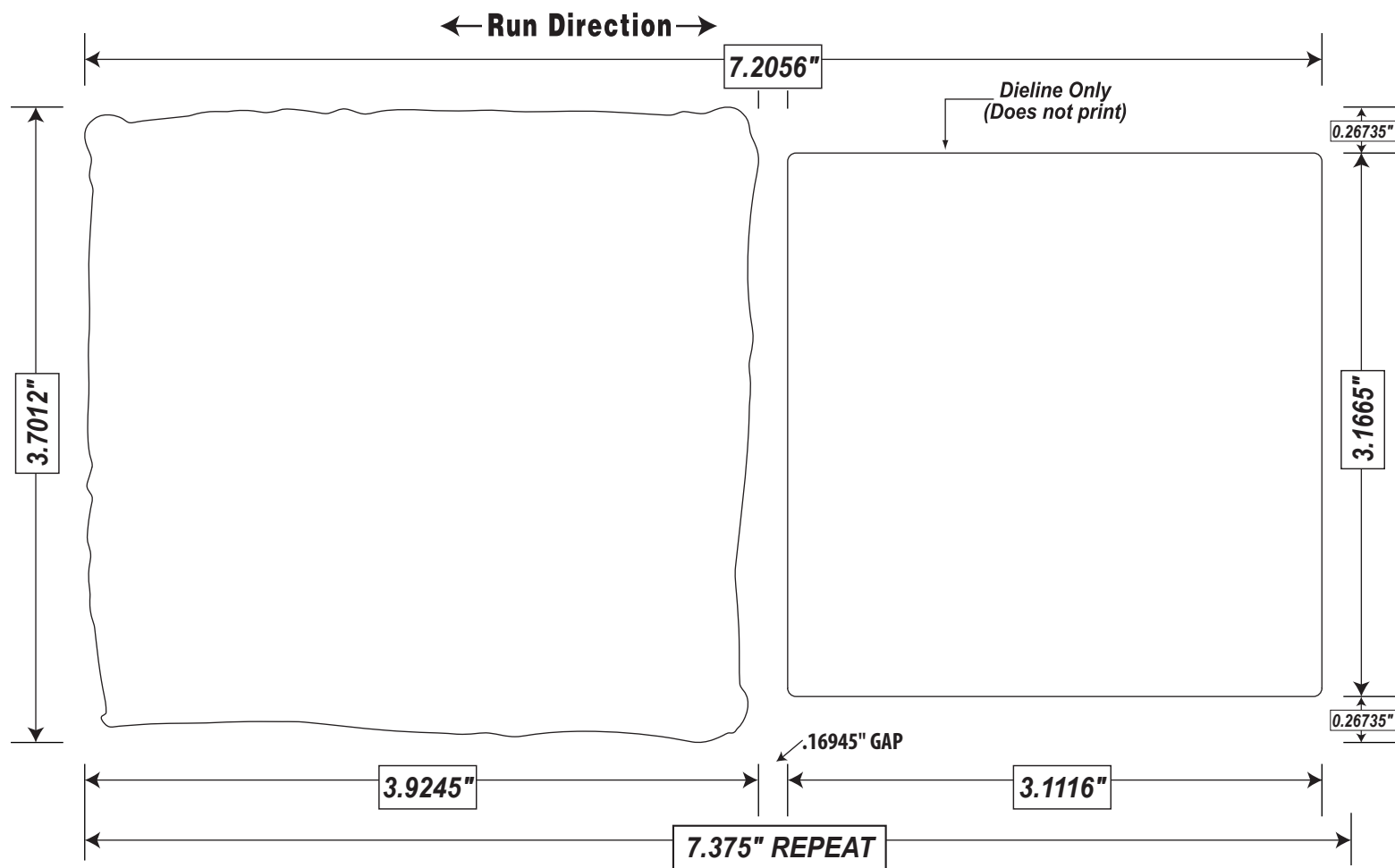

**Die#: V-168**  
**Size: 2.75" x 7.5625"**  
**Corners: 1/64"**  
**Material Type: Classic Crest**  
**Varnish: Matte**  
**Laminate: None**  
**Special tooling: Sculpted Emboss**

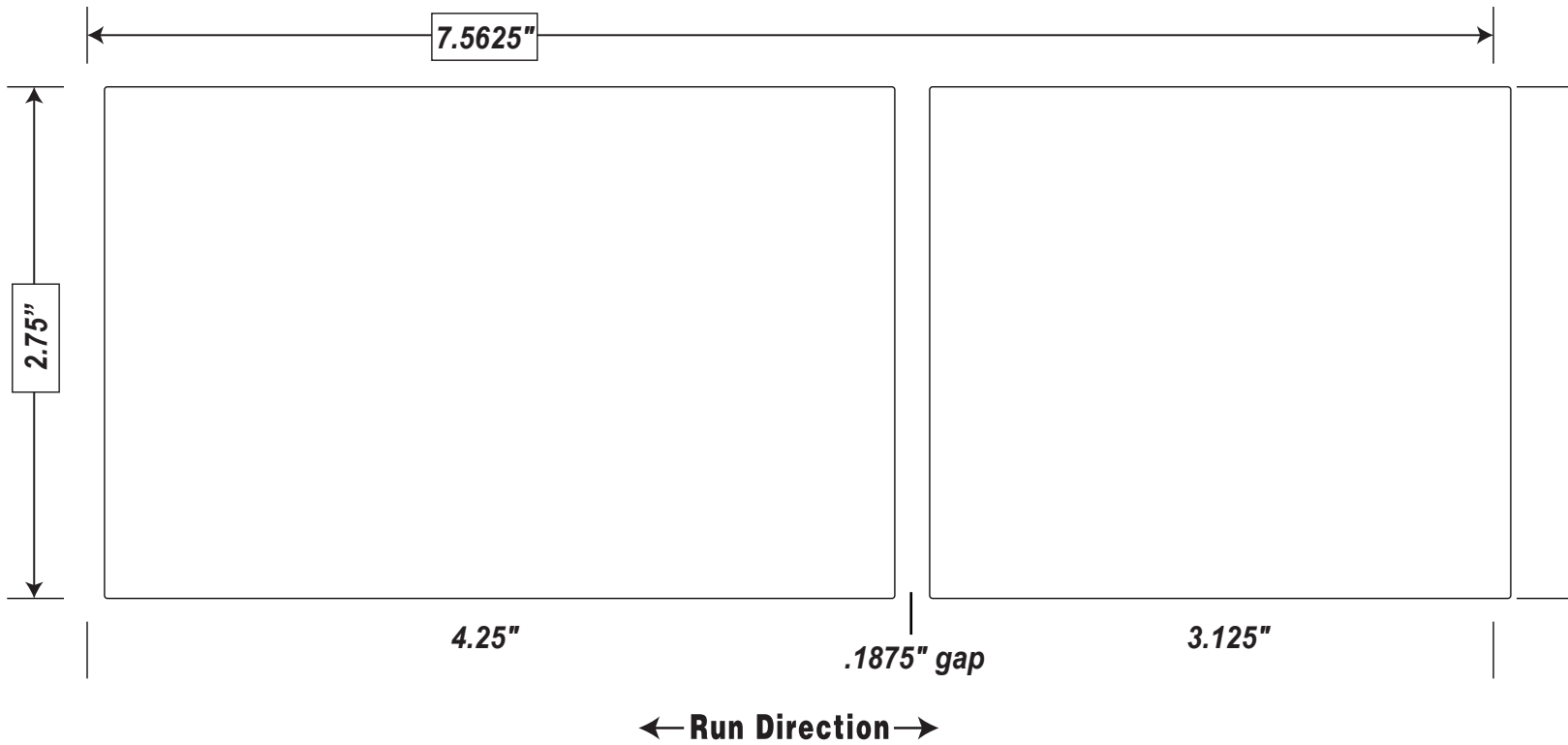

Die#: V-170  
Size: 2.91" X 8.59"  
Corners: 1/64"  
Material Type: Eggshell Felt  
Varnish: yes - satin coat 2  
Laminate: none  
Special tooling: none

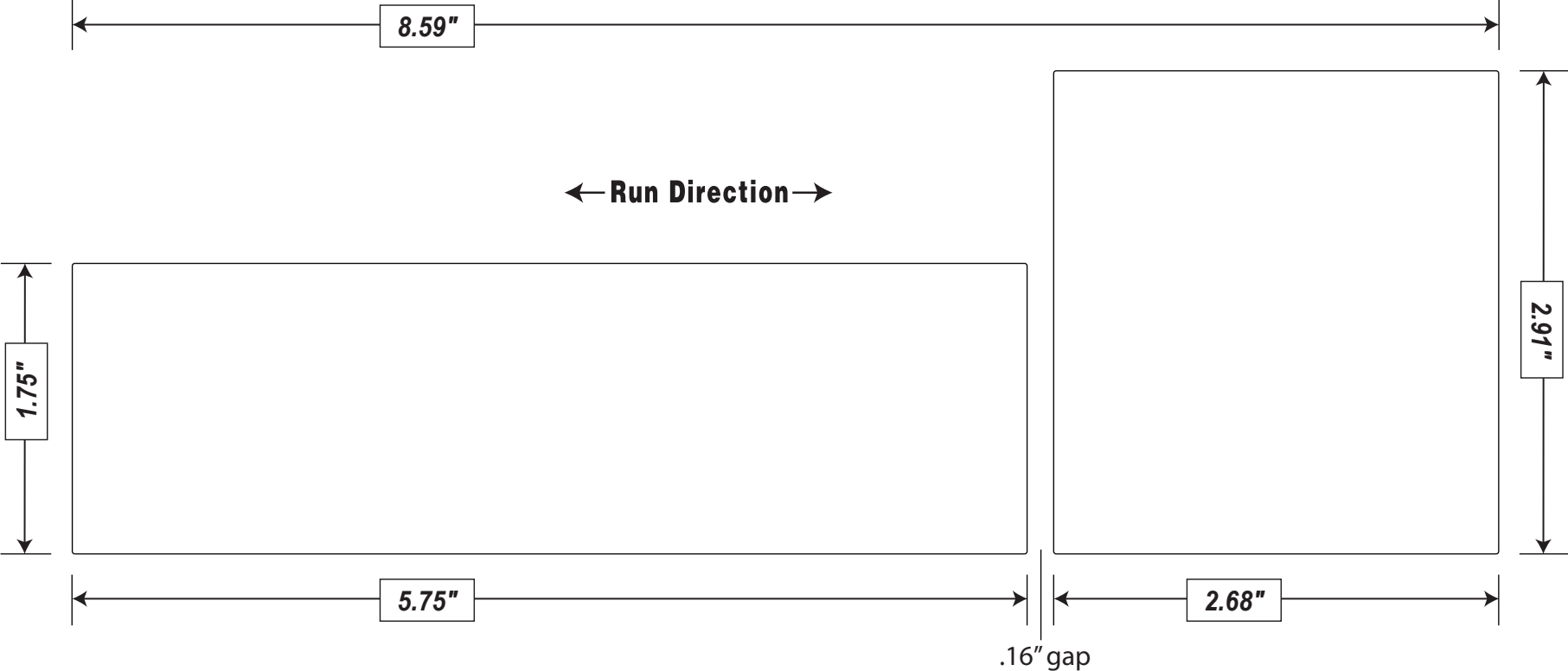

Die#/Size: V-191 4 x 6.375  
Corners: .015625  
Material Type: Classic Felt  
Varnish: ?  
Laminate: no  
Special tooling: no

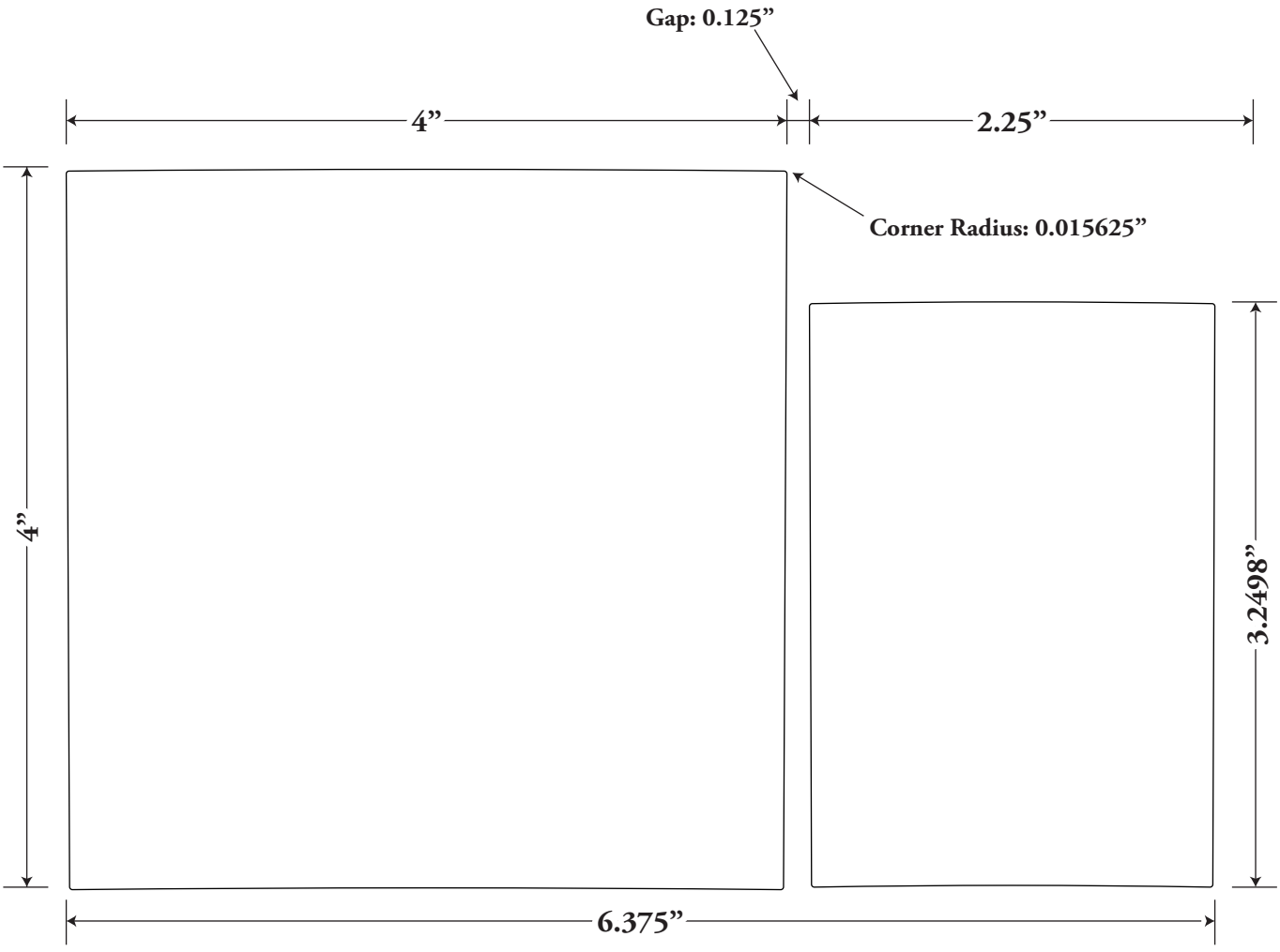

**Die#/Size:** V-193: 3.75" X 6.125"  
**Corners:** 1/64"  
**Material Type:** Classic Crest  
**Varnish:** Matte Crystal Barrier  
**Laminate:** None  
**Special tooling:** None

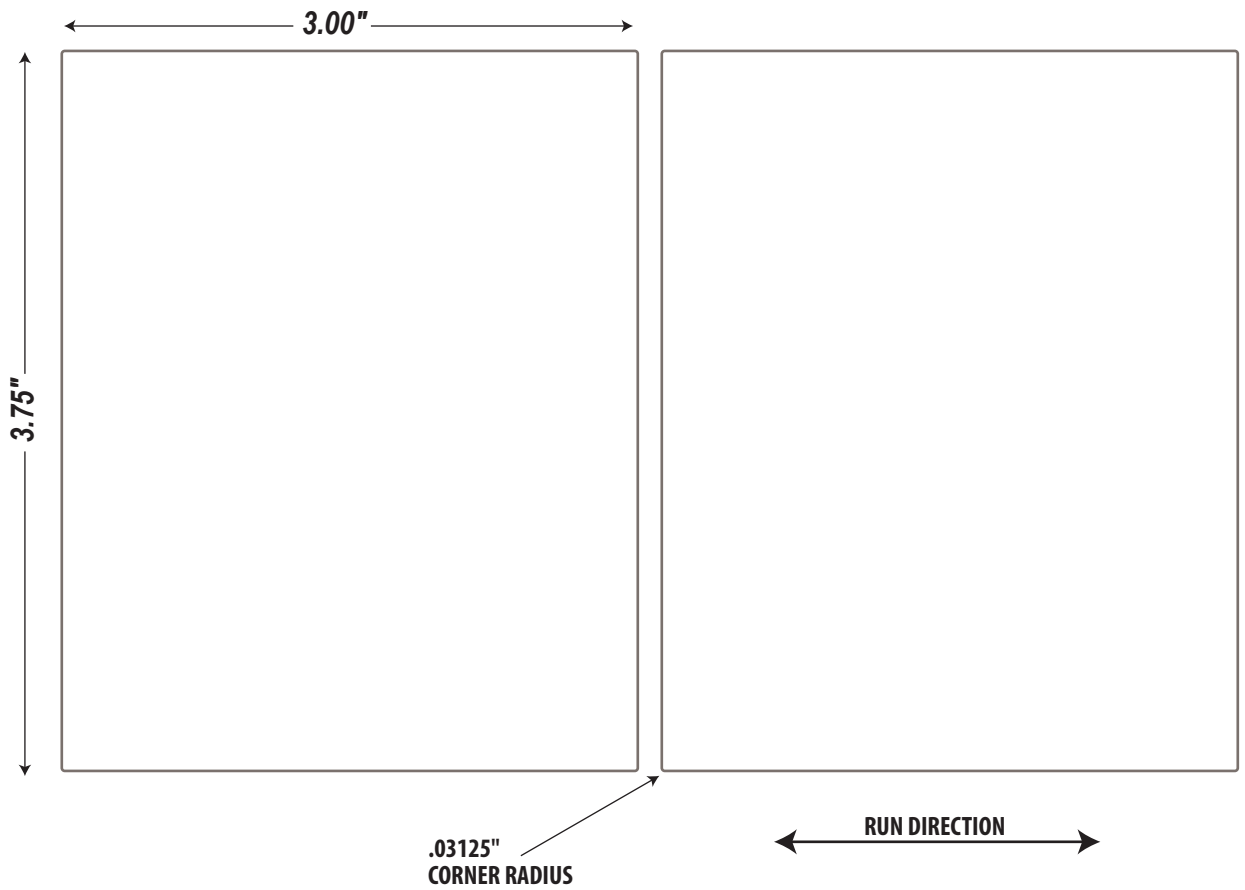

Die#: V-199  
Size: 5" x 5.125"  
Corners: 1/64"  
Material Type: CLASSIC CREST  
Varnish: GLOSS UV  
Laminate: NONE  
Special tooling: NONE

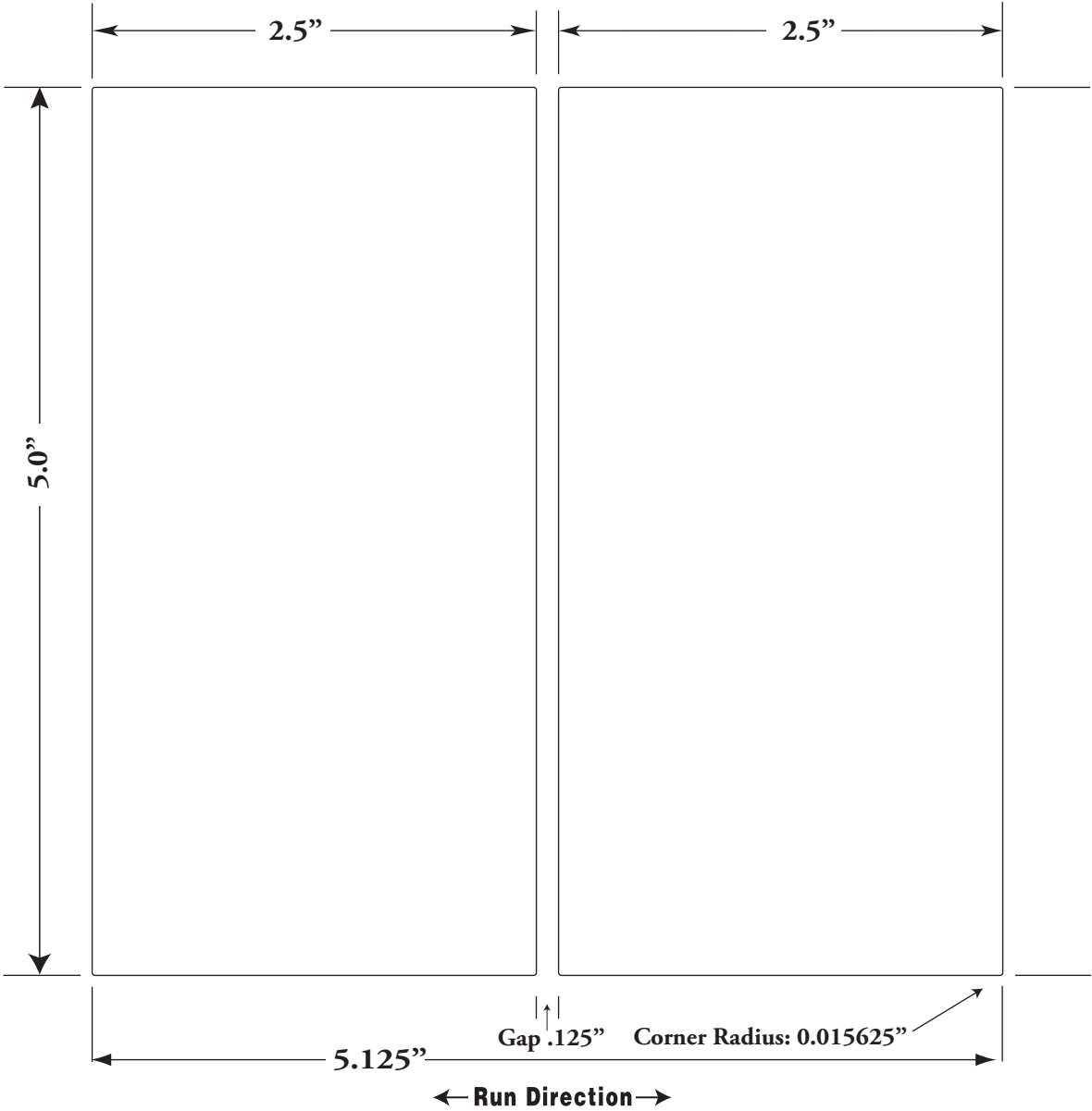

Die#: V-200  
Size: 4" x 8.125"  
Corners: 1/64"  
Material Type: CLASSIC CREST  
Varnish: GLOSS  
Laminate: NONE  
Special tooling: NONE

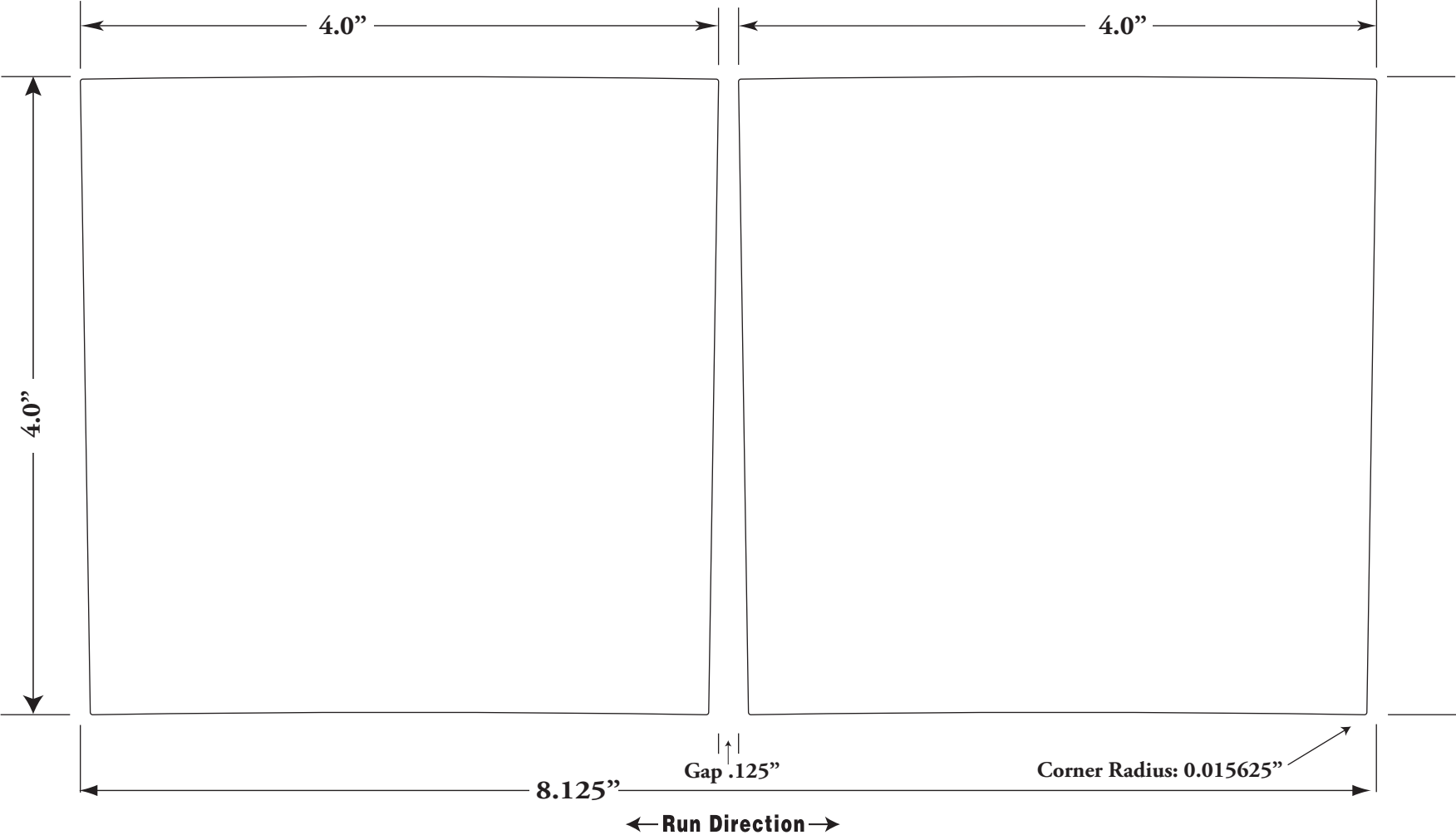

**Die#: V-203**

**Size: 5.75" x 5.625"**

**Corners: 1/64"**

**Material Type: Classec Felt**

**Varnish: Gloss Crystal Barrier**

**Laminate: none**

**Special tooling: none**

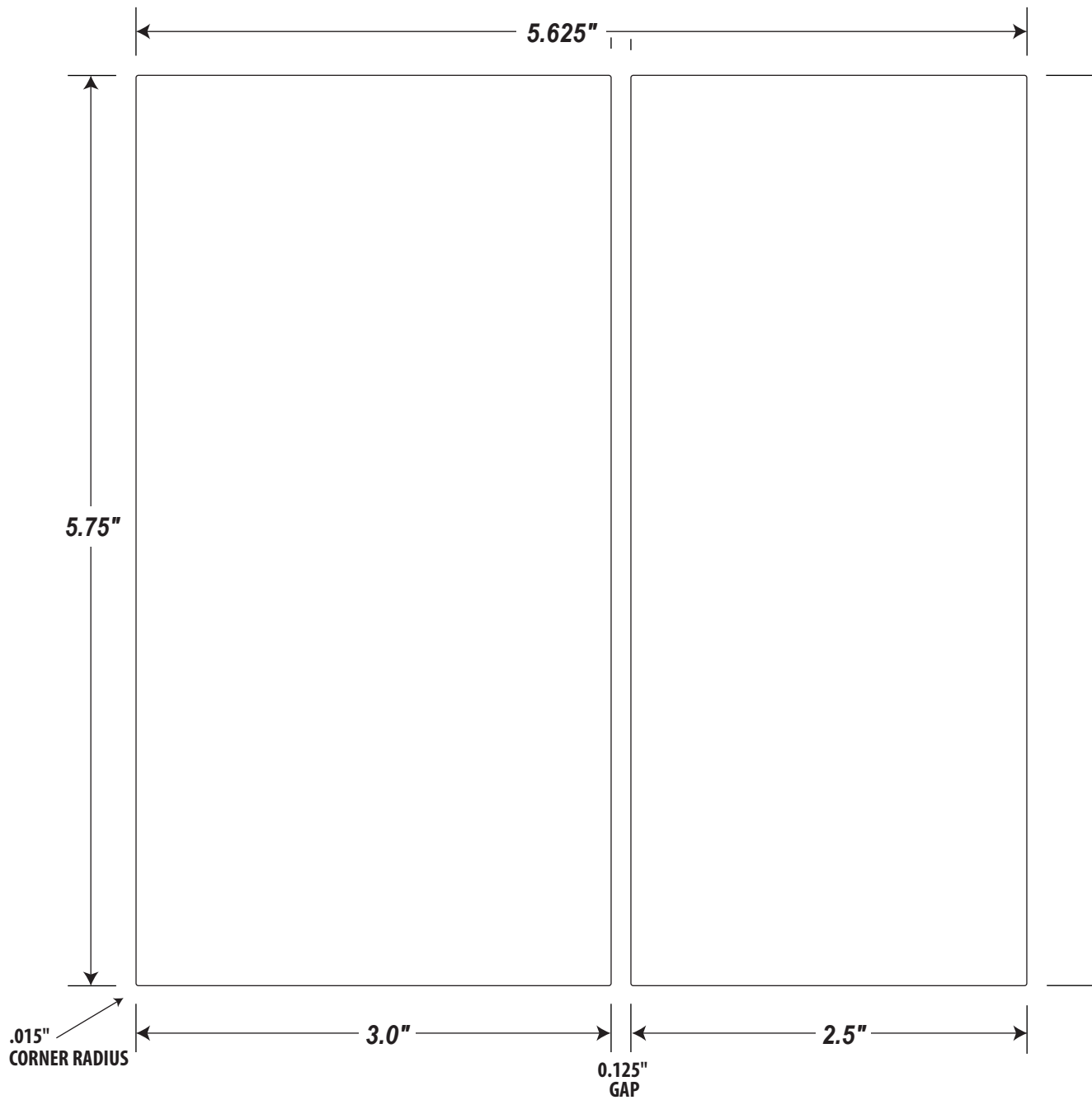

Die#: V-204  
Size: 4" x 6.375"  
Corners: 1/64"  
Material Type: Classec Felt  
Varnish: Gloss Crystal Barrier  
Laminate: none  
Special tooling: none

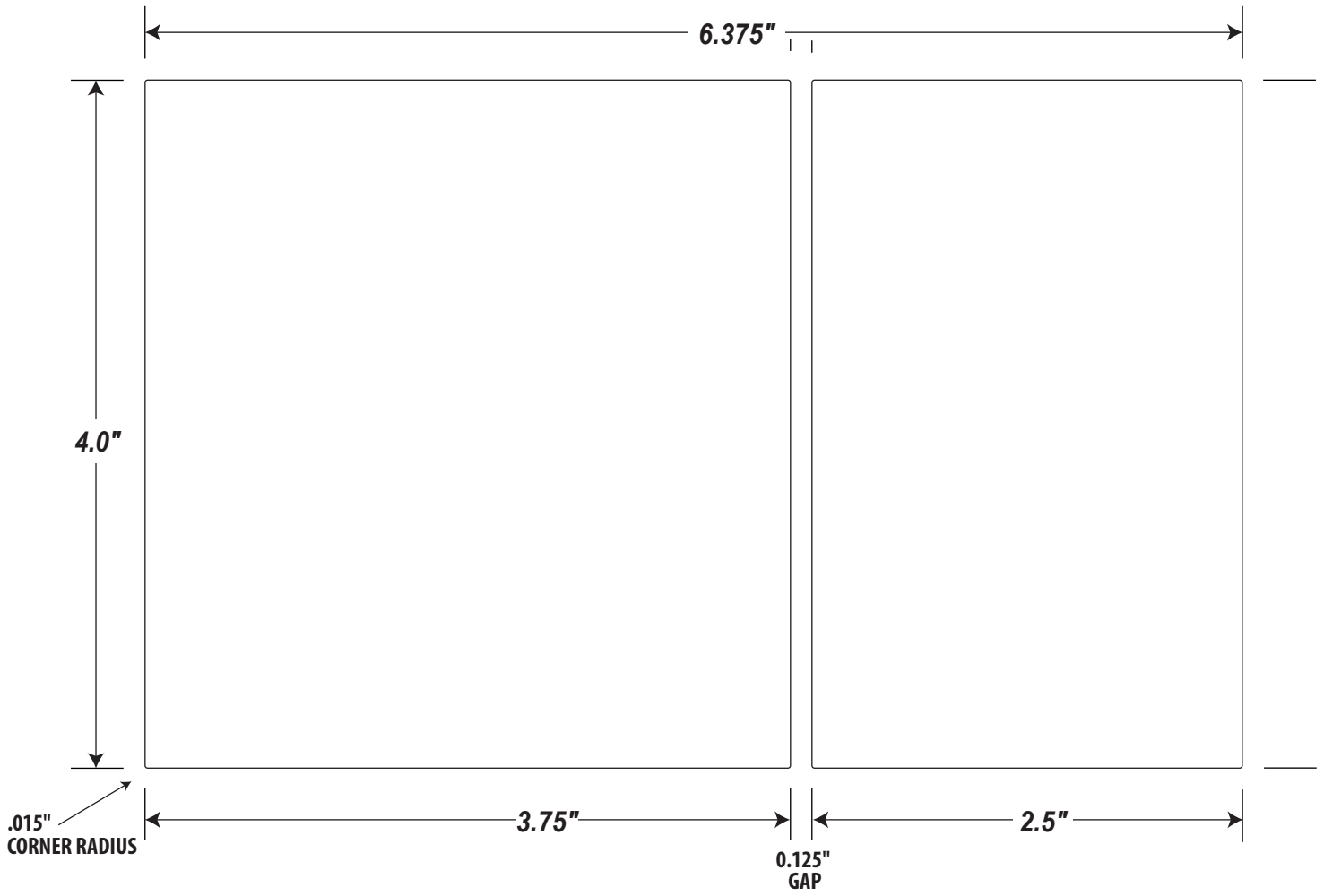

**DIE#** V-206  
**SIZE:** 5.8 x 3.125 "  
**CORNERS:** 0.0156 "  
**MATERIAL TYPE:** Clear Bopp  
**VARNISH:** none  
**LAMINATE:** no  
**SPECIAL TOOLING:** die

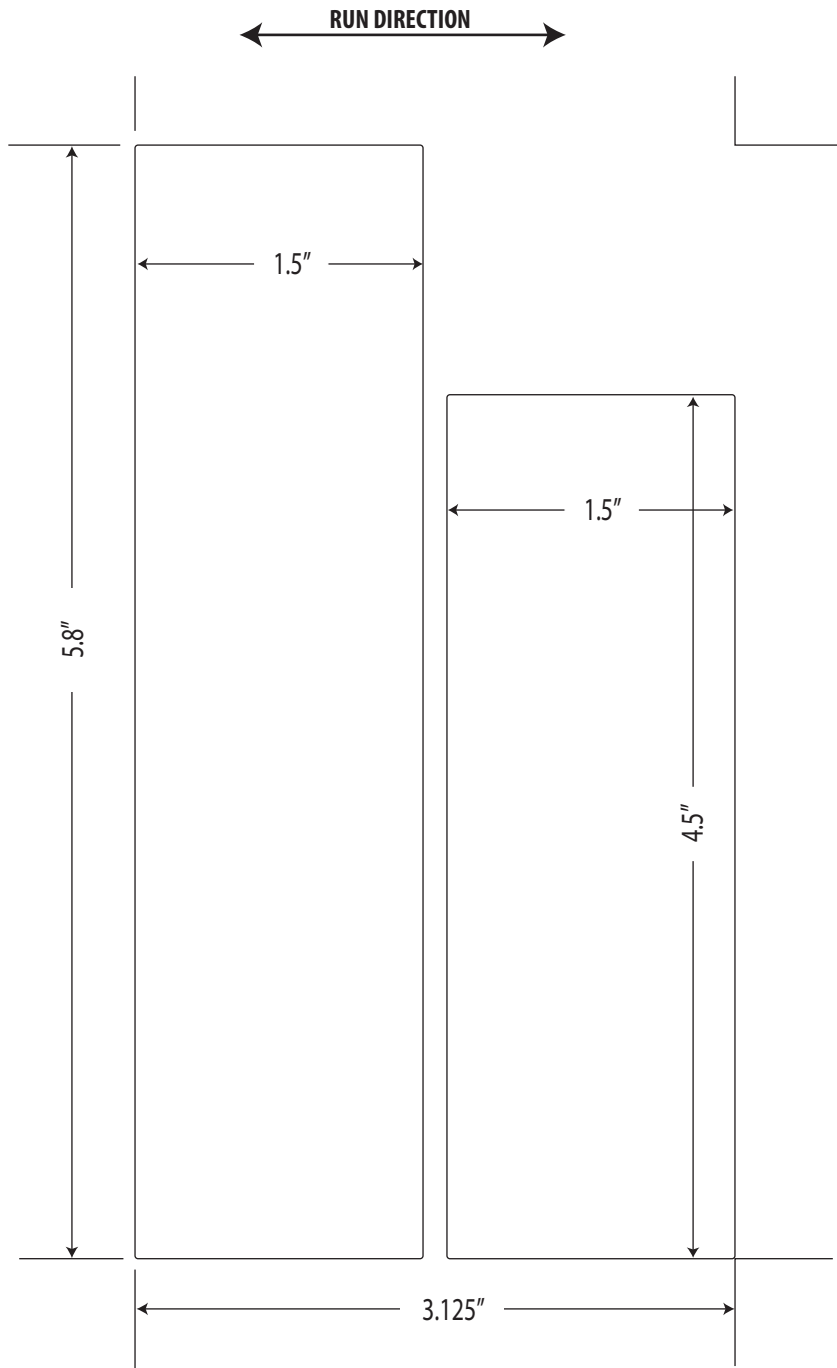

**Die#/Size:** V-208 4.5" x 6.375"  
**Corners:** 1/64" (0.015)  
**Material Type:** Estate #4  
**Varnish:** matte varn  
**Laminate:** None  
**Special tooling:** None

← **Run Direction** →

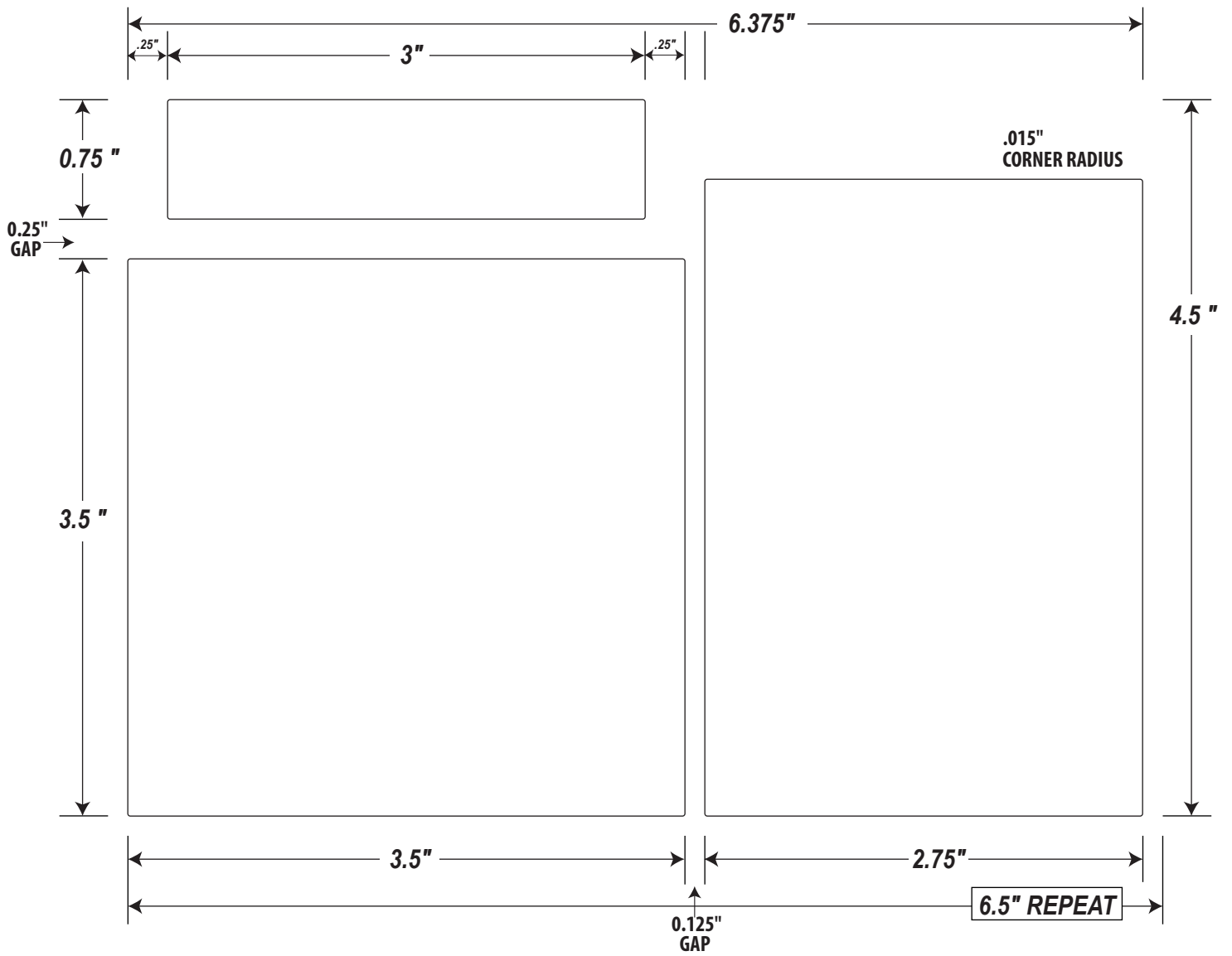

Die#: V-211  
Size: 3.8343" x 8.68"  
Corners: n/a - special shape  
Material Type: Estate #8  
Varnish: matte crystal barrier  
Laminate: none  
Special tooling: none

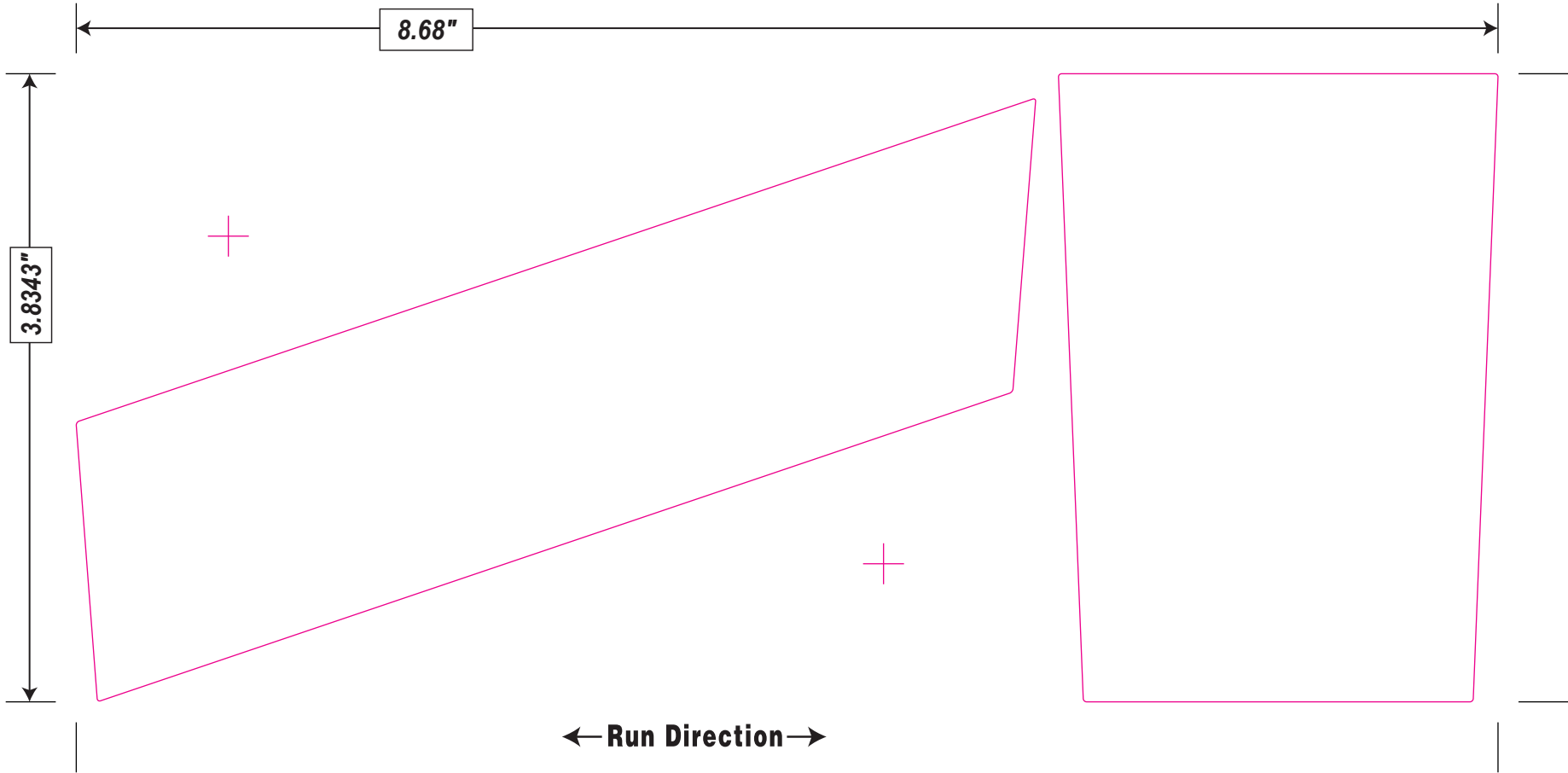

Die#:V-213  
Size: 4.125" x 5.25"  
Corners: 0.015"  
Material Type: Classic Crest  
Varnish: TBD  
Laminate:  
Special tooling:

← Run Direction →

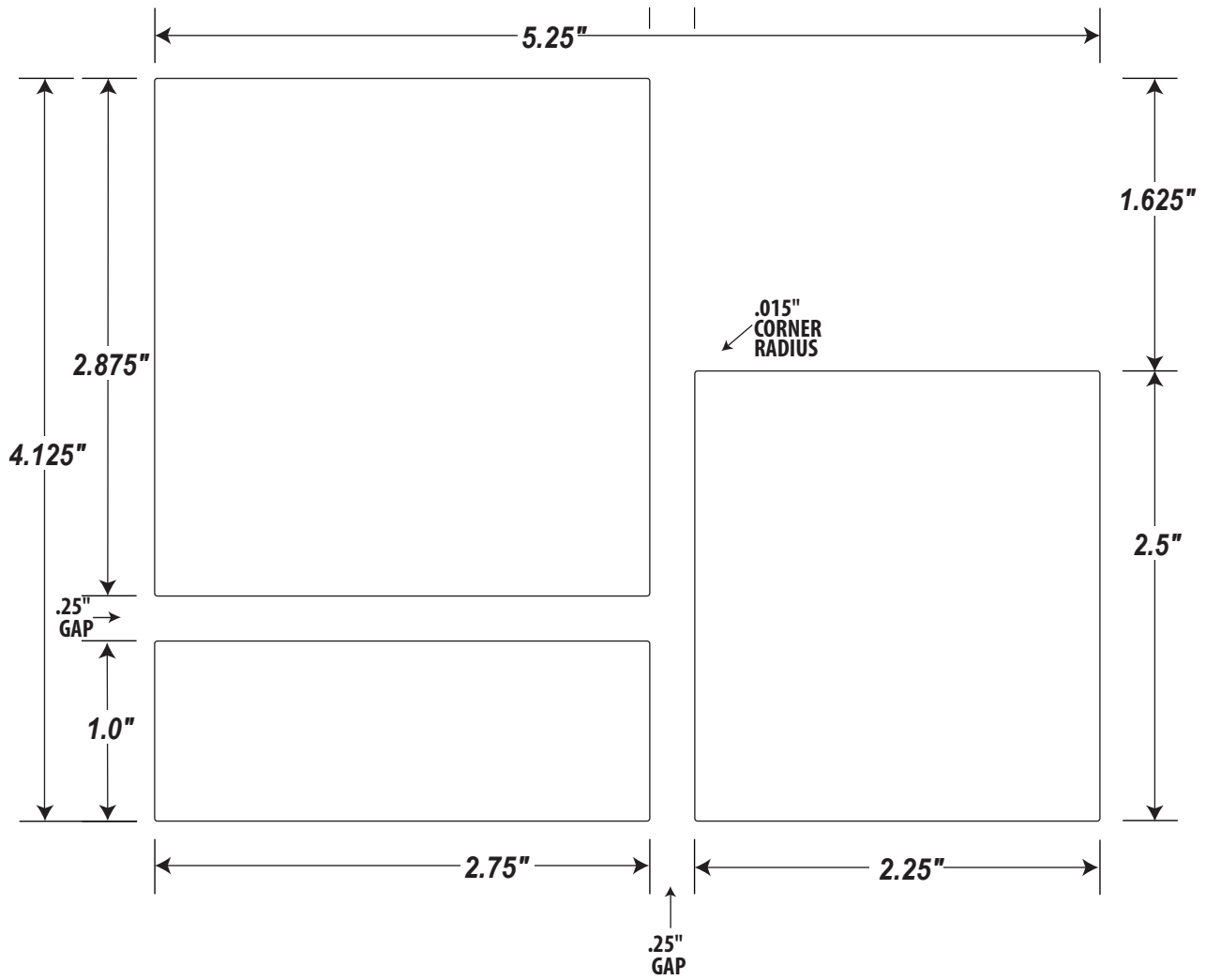

**DIE#** V-216  
**SIZE:** 2.25" X 3.5"  
**CORNERS:** 0.125"  
**MATERIAL TYPE:** Classic Crest  
**VARNISH:** Matte Crystal  
**LAMINATE:** none  
**SPECIAL TOOLING:** none

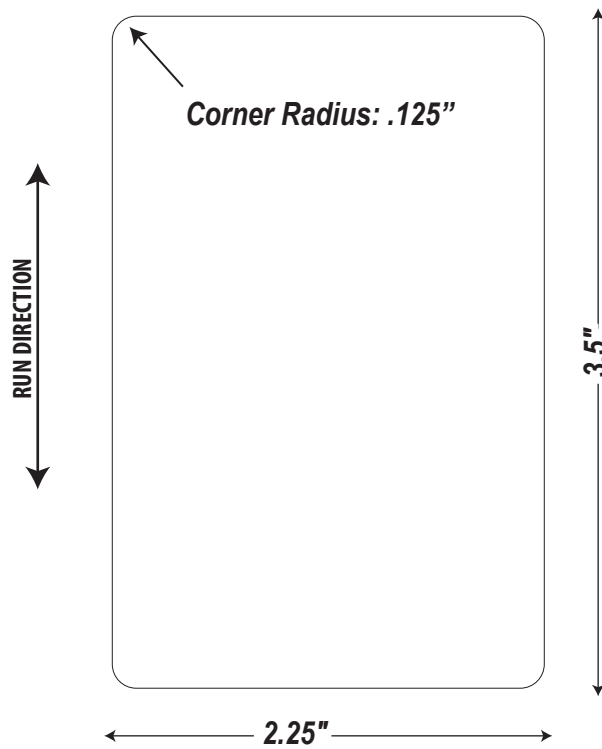

Die#: V-217  
Size: 4.95" x 6.0"  
Corners: 0.015"  
Material Type: Classic Crest  
Varnish: TBD  
Laminate:  
Special tooling:

← Run Direction →

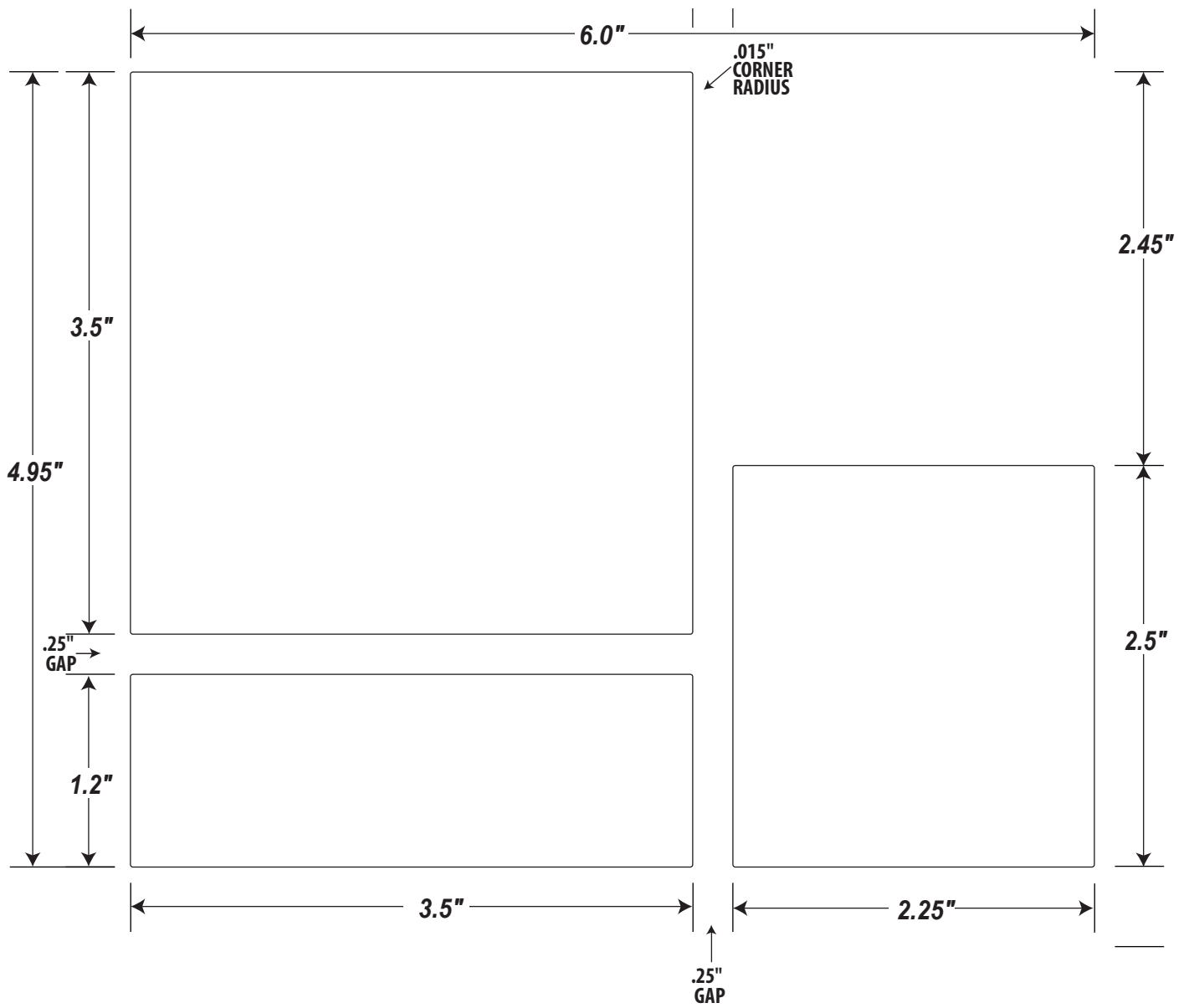

**Die#/Size:** V-218 3.9375" x 2.0"

**Corners:**

**Material Type:** Wet Strength Matte

**Varnish/Laminate:** Spot UV, Matte Barrier

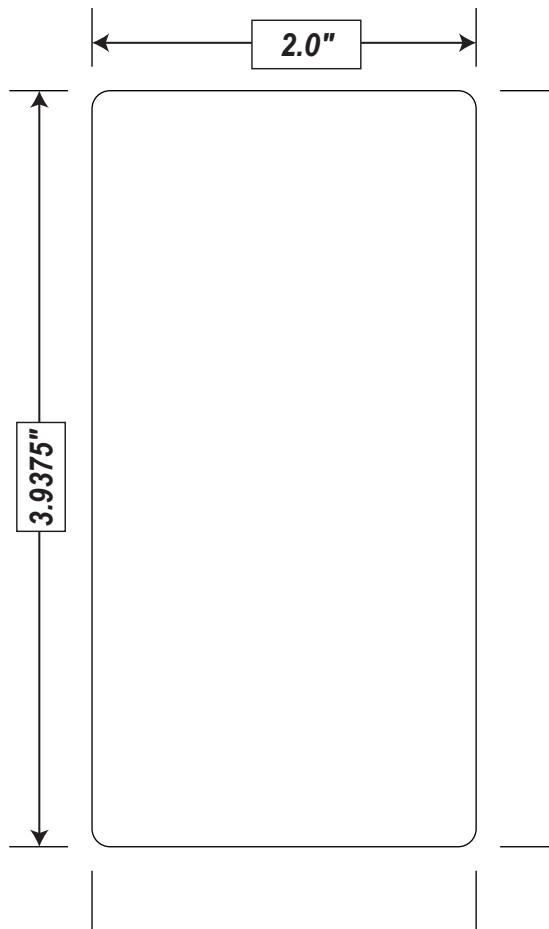

← **Run Direction** →

Die#: V-221  
Size: 4" x 6.25"  
Corners: .03125"  
Material Type: Wine  
Varnish: Spot UV  
Laminate: Classic Crest Selfwound  
Special tooling: Emboss

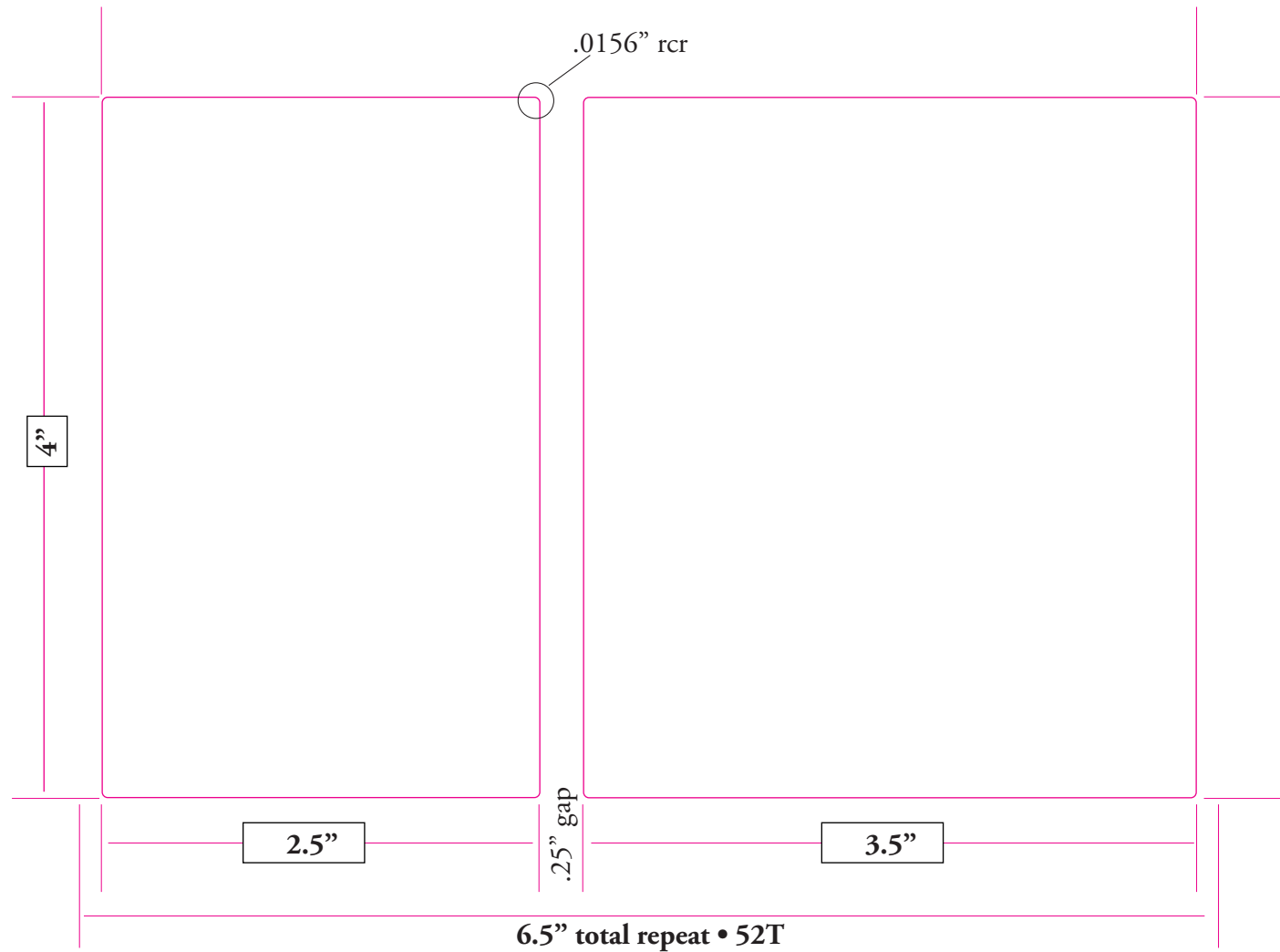

← Run Direction →

V-223 5.125" X 7"  
1/64"  
Classic Felt  
Matte Crystal Barrier  
None  
Special

← Run Direction →

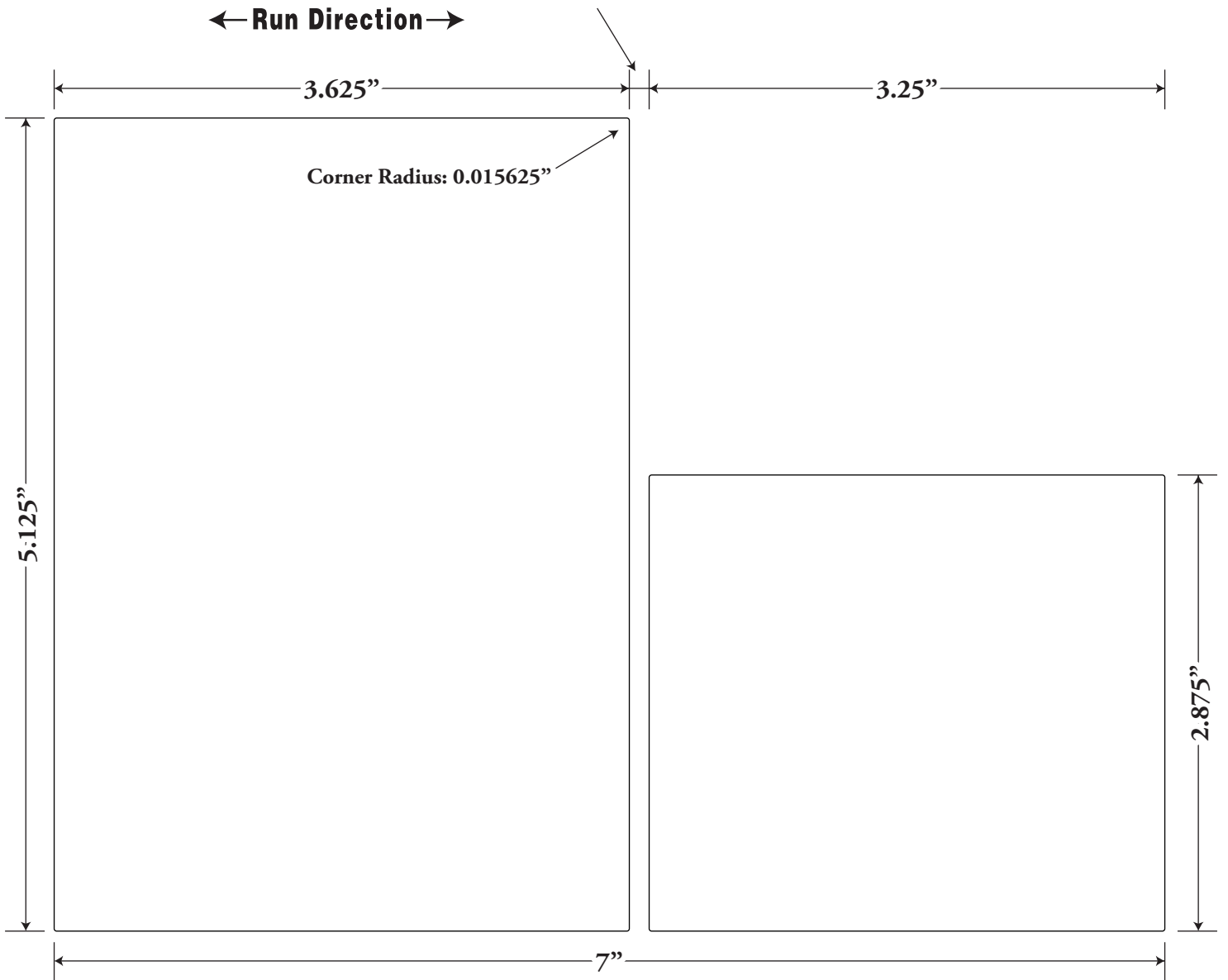

Die#: V-224  
Size: 3.75" x 6.5"  
Corners: 1/64"  
Material Type: Bright Silver Foil  
Varnish: UV  
Laminate: no  
Special tooling: no

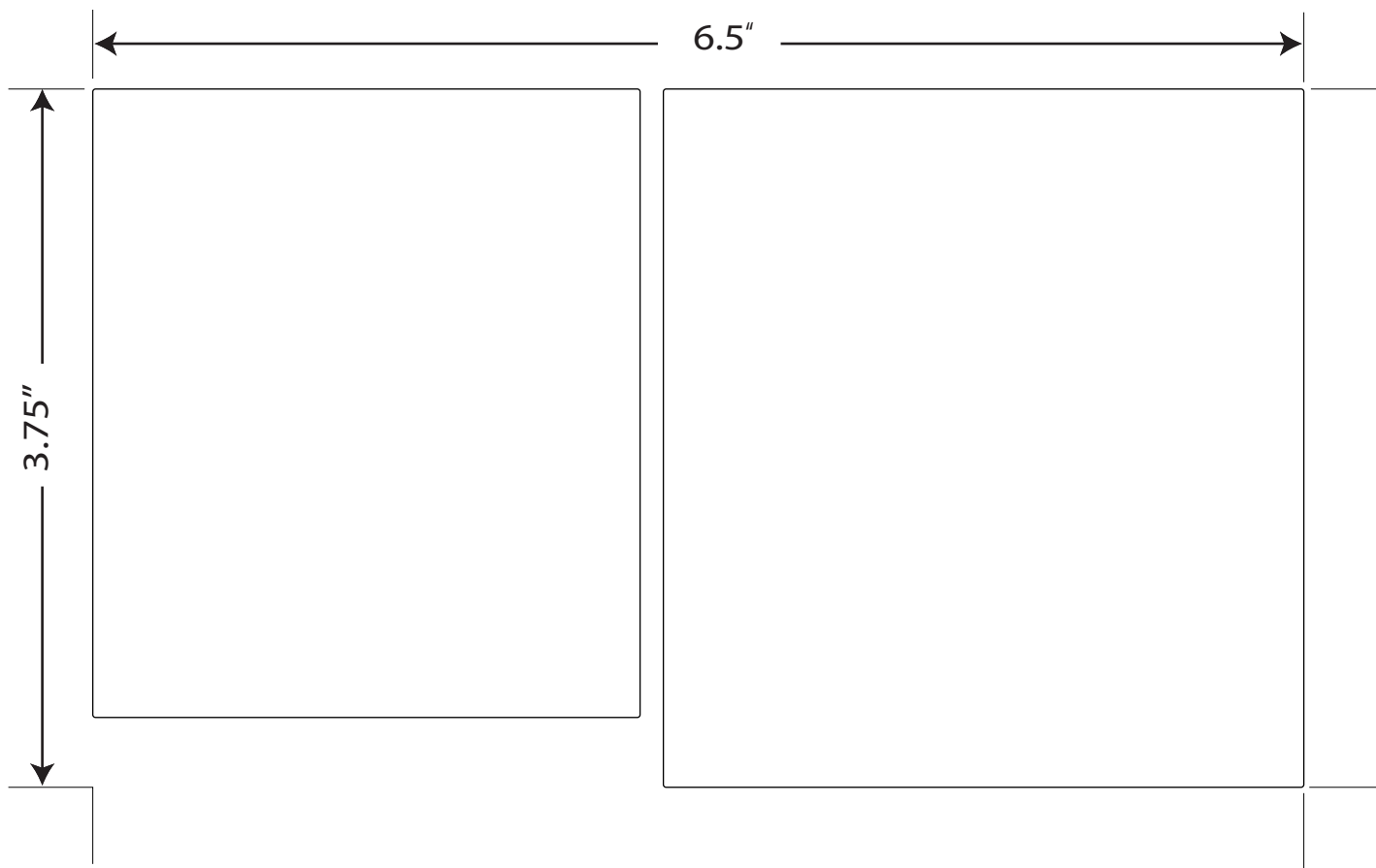

← Run Direction →

Die#: V-226  
Size: 4.5" x 5.625"  
Corners: .015625"  
Material Type: Eggshell Felt  
Varnish: none  
Laminate: none  
Special tooling: none

← Run Direction →

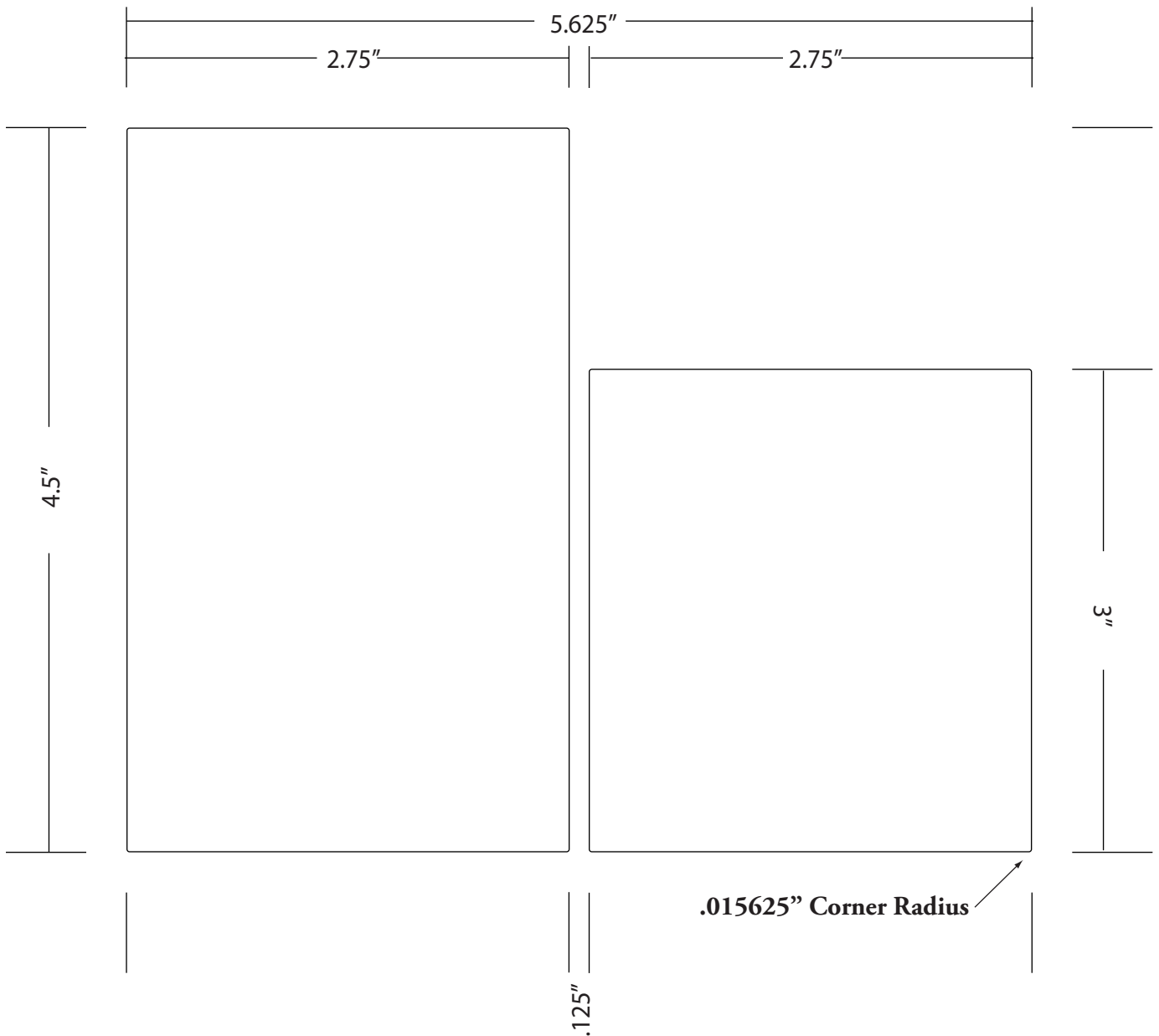

**Die#: V-228**

**Size: 3 x 4.5"**

**Corners: 1/64" (.0156")**

**Material Type: Classic Crest**

**Varnish: Spot UV**

**Laminate:**

**Special tooling: new die**

**← Run Direction →**

4.5"



3"

1.64" corners

**Die#: V-229**  
**Size: 3 x 2.875"**  
**Corners: 1/64" (.0156")**  
**Material Type: Classic Crest**  
**Varnish: Spot UV**  
**Laminate:**  
**Special tooling: new die**

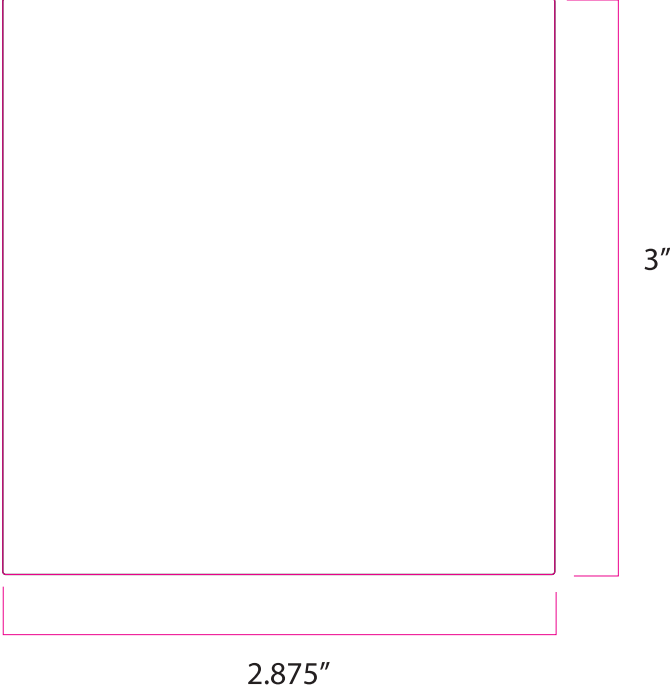

**← Run Direction →**

Die#: V-240  
Size: 3.685" X 7.325"  
Corners: 1/64"  
Material Type: Classic Crest  
Varnish: yes  
Laminate: no  
Special tooling: none

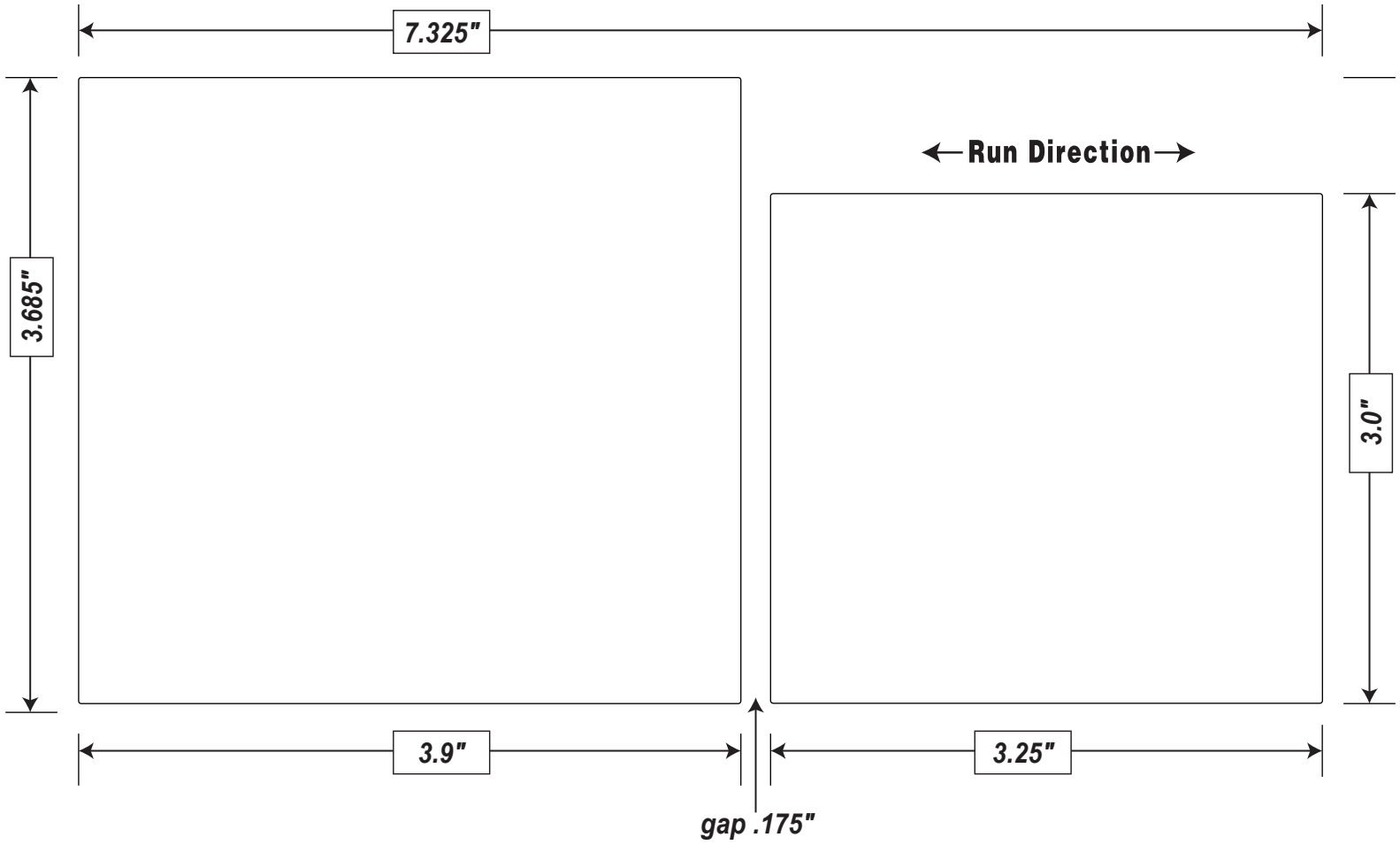

Die#: V-242  
Size: 3.5" x 8.125"  
Corners: .0156"  
Material Type: Classic Crest  
Varnish: none  
Laminate: none  
Special tooling: none

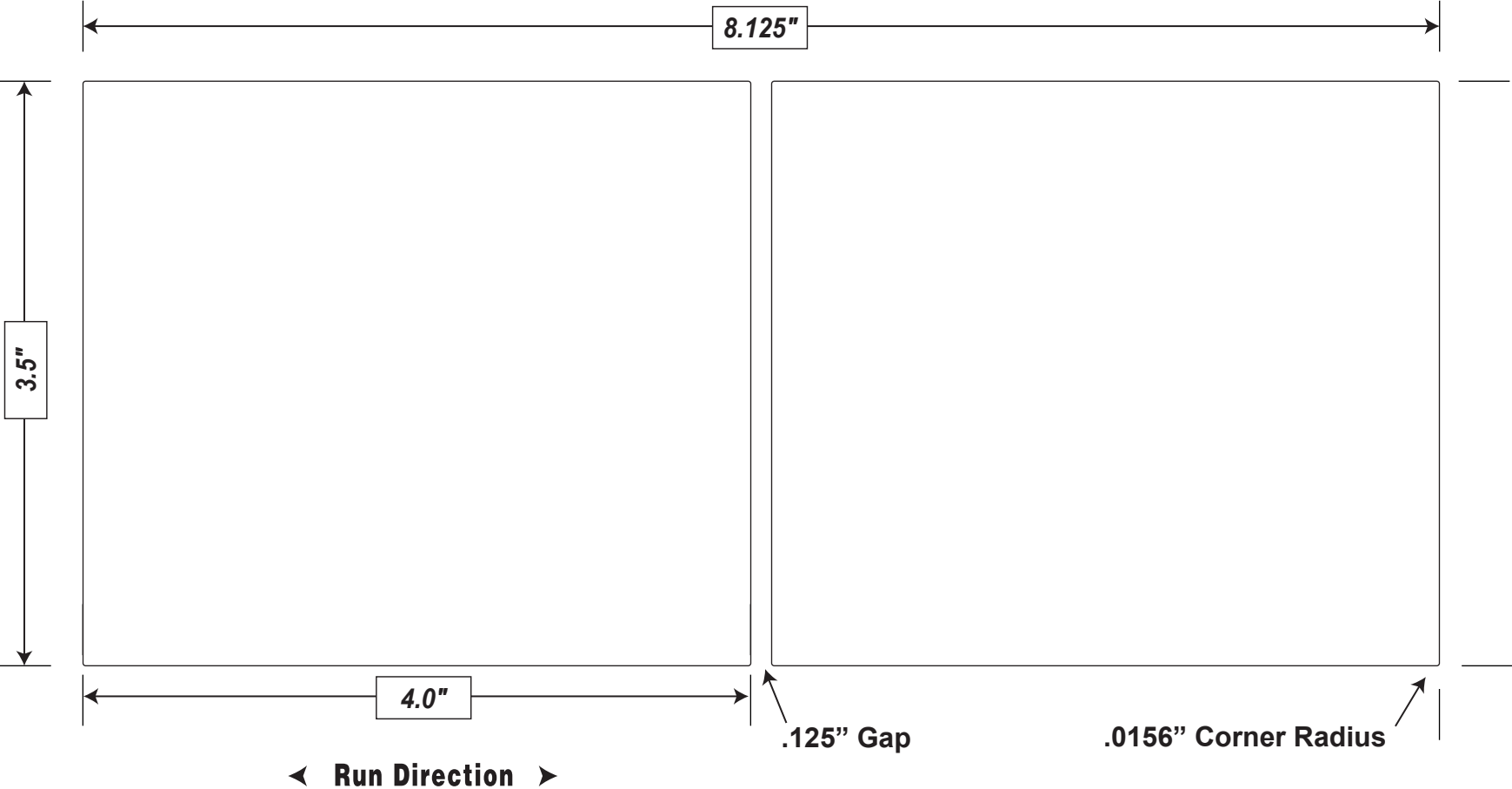

**Die#: V-243**

**Size: 1.6374" x 10.35"**

**Corners: .0156"**

**Material Type: Classic Crest**

**Varnish: matte crystal**

**Laminate: none**

**Special tooling: none**

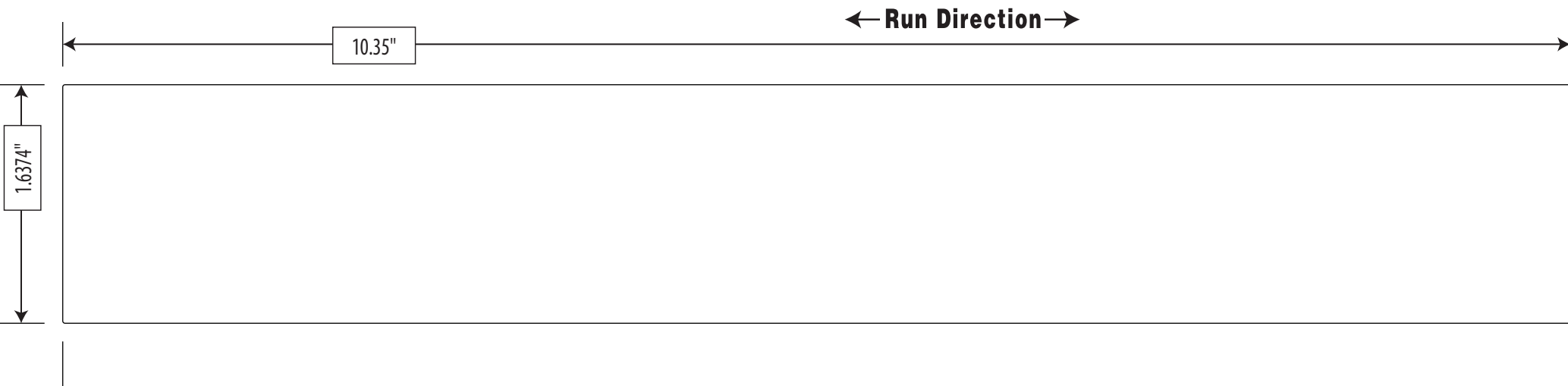

Die#: V-244  
Size: 2.4175" x 10.35"  
Corners: .0156"  
Material Type: Classic Crest  
Varnish: matte crystal  
Laminate: none  
Special tooling: none

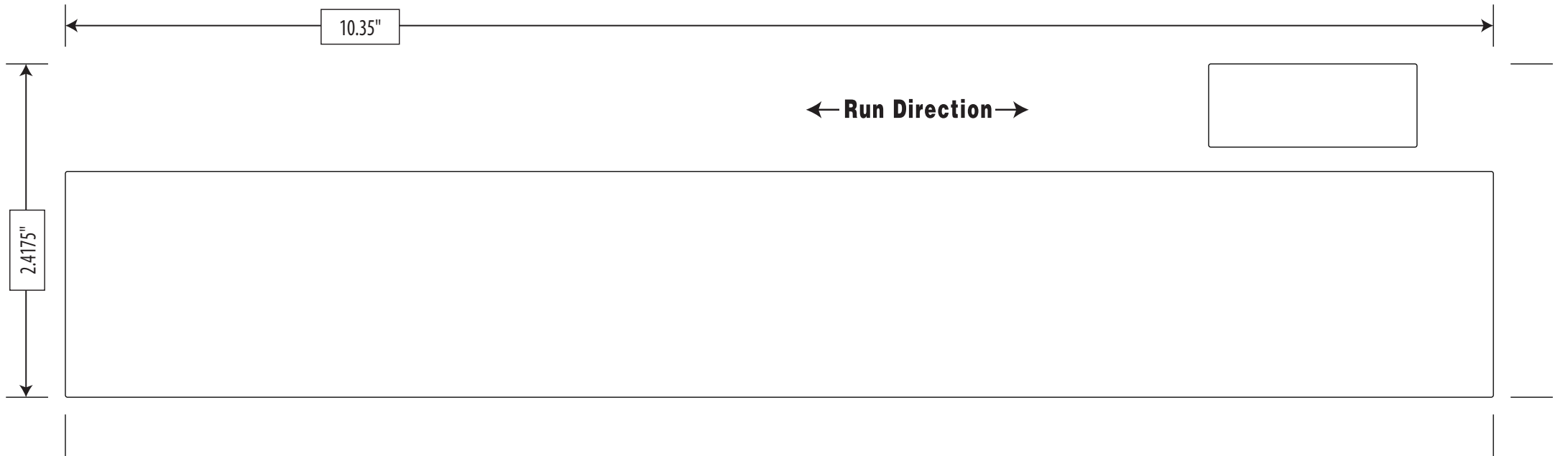

Die#: V-246  
Size: 4.75" x 5.625"  
Corners: 1/64"  
Material Type: Classic Felt  
Varnish: Gloss Crystal Barrier  
Laminate: none  
Special tooling: none

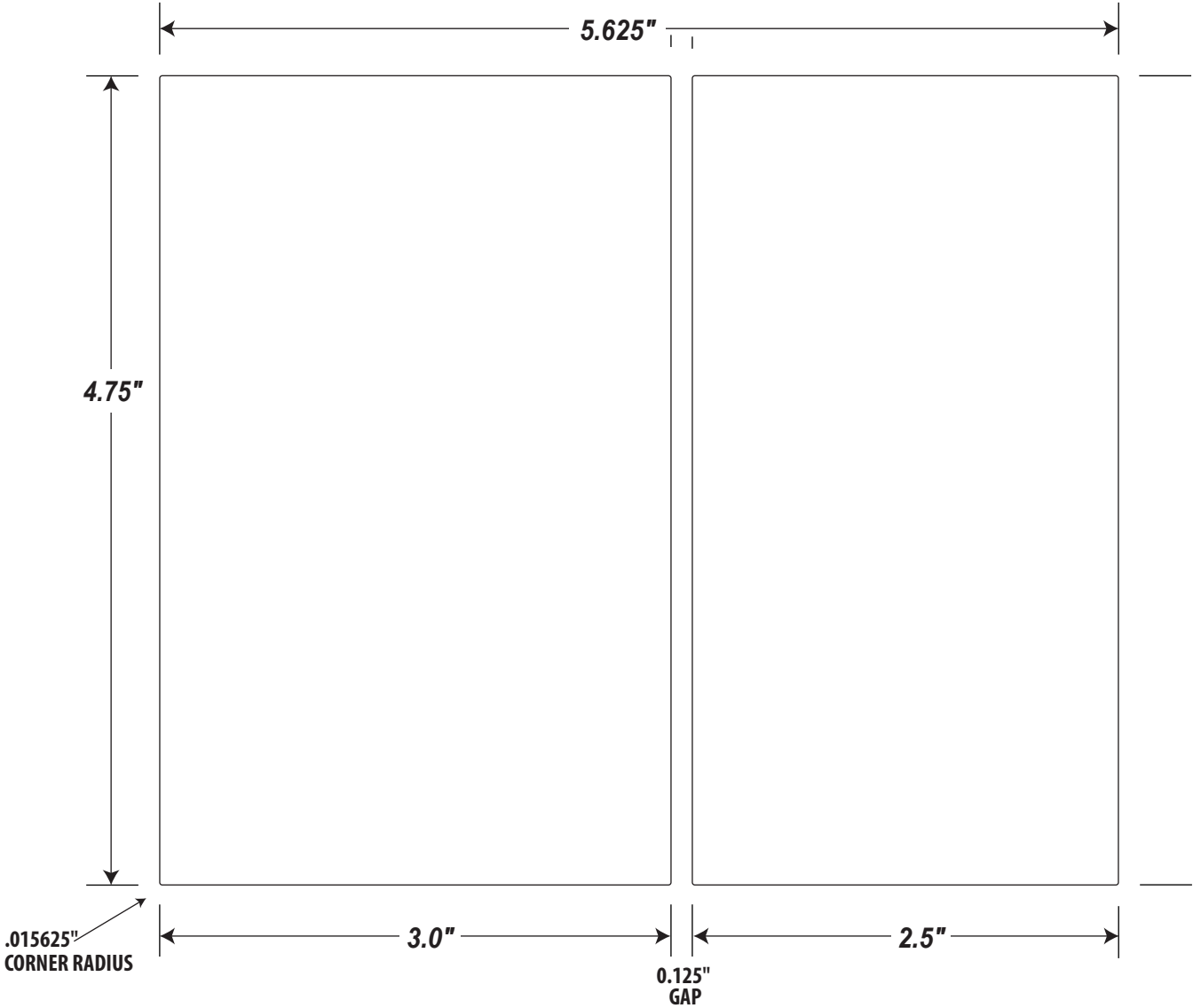

**Die#: V-248**  
**Size: 1.6374" x 9.35"**  
**Corners: .015625"**  
**Material Type: Classic Crest**  
**Varnish: matte crystal**  
**Laminate: none**  
**Special tooling: none**

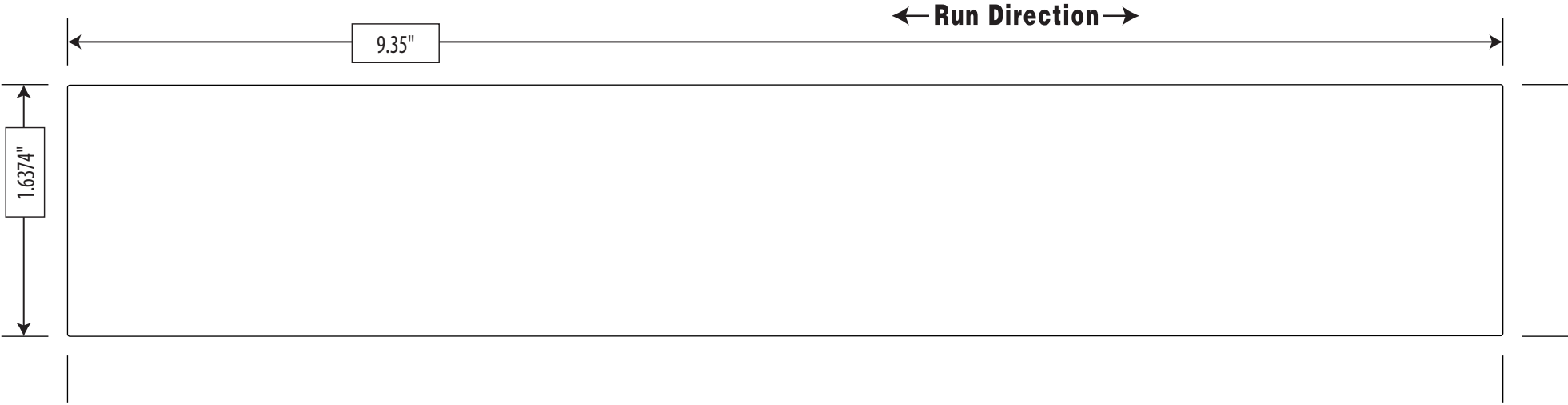

Die#: V-249  
Size: 2.4175" x 9.35"  
Corners: .015625"  
Material Type: Classic Crest  
Varnish: matte crystal  
Laminate: none  
Special tooling: none

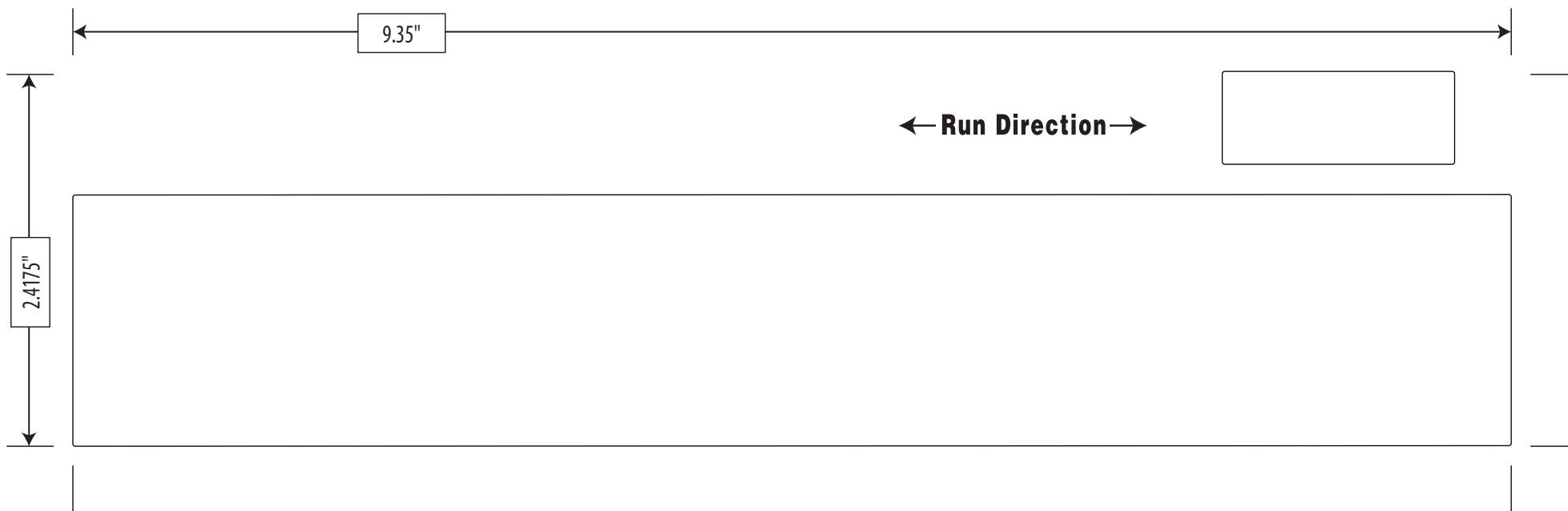

Die#: V-250  
Size: 4" x 6.25"  
Corners: 1/64"  
Material Type: classic felt  
Varnish: gloss  
Laminate: none  
Special tooling: none

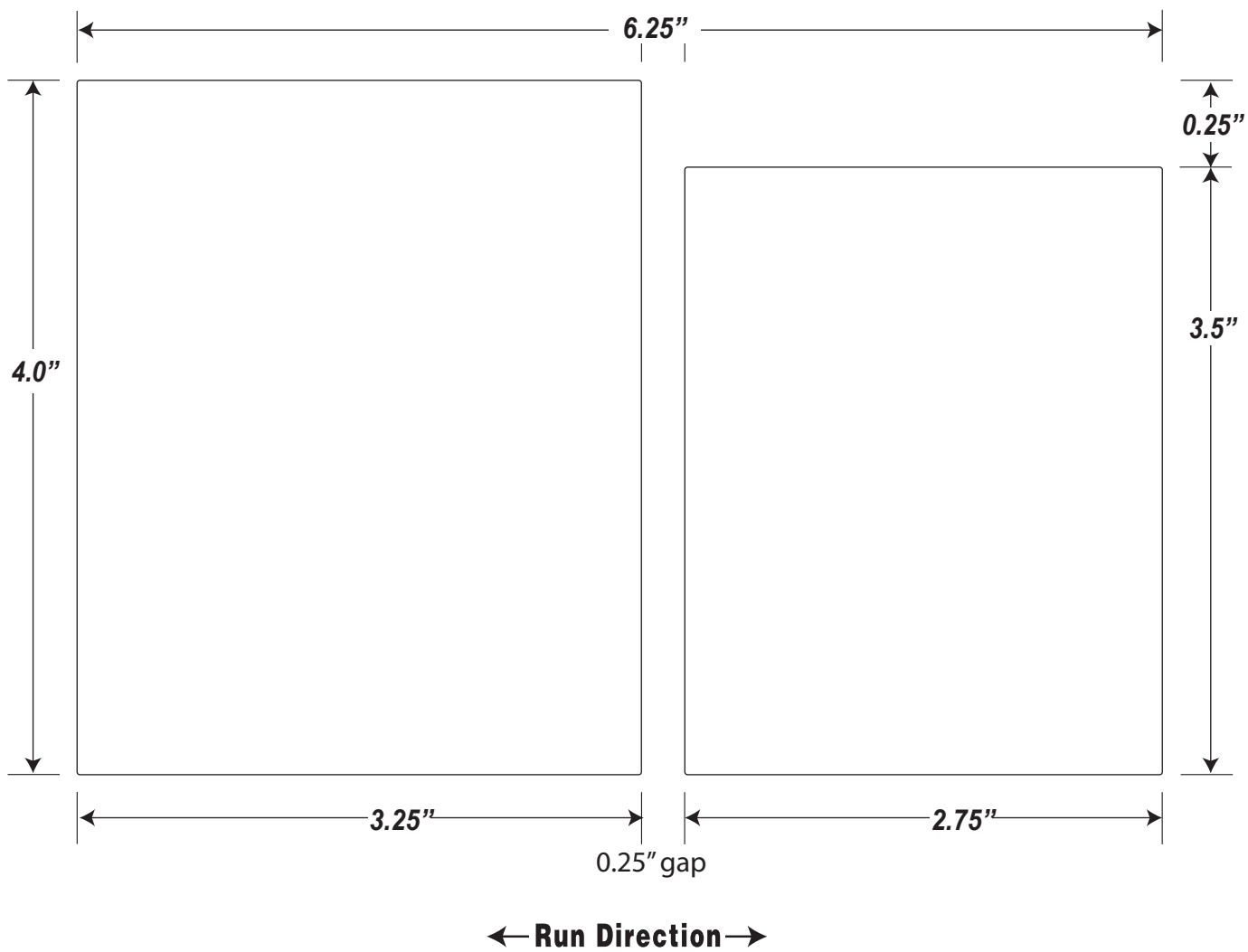

**Die#/Size:** V-257 3" x 7.25"  
**Corners:** 1/32"  
**Material Type:** Estate #4  
**Varnish:** gloss crystal barrier  
**Laminate:** None  
**Special tooling:** None

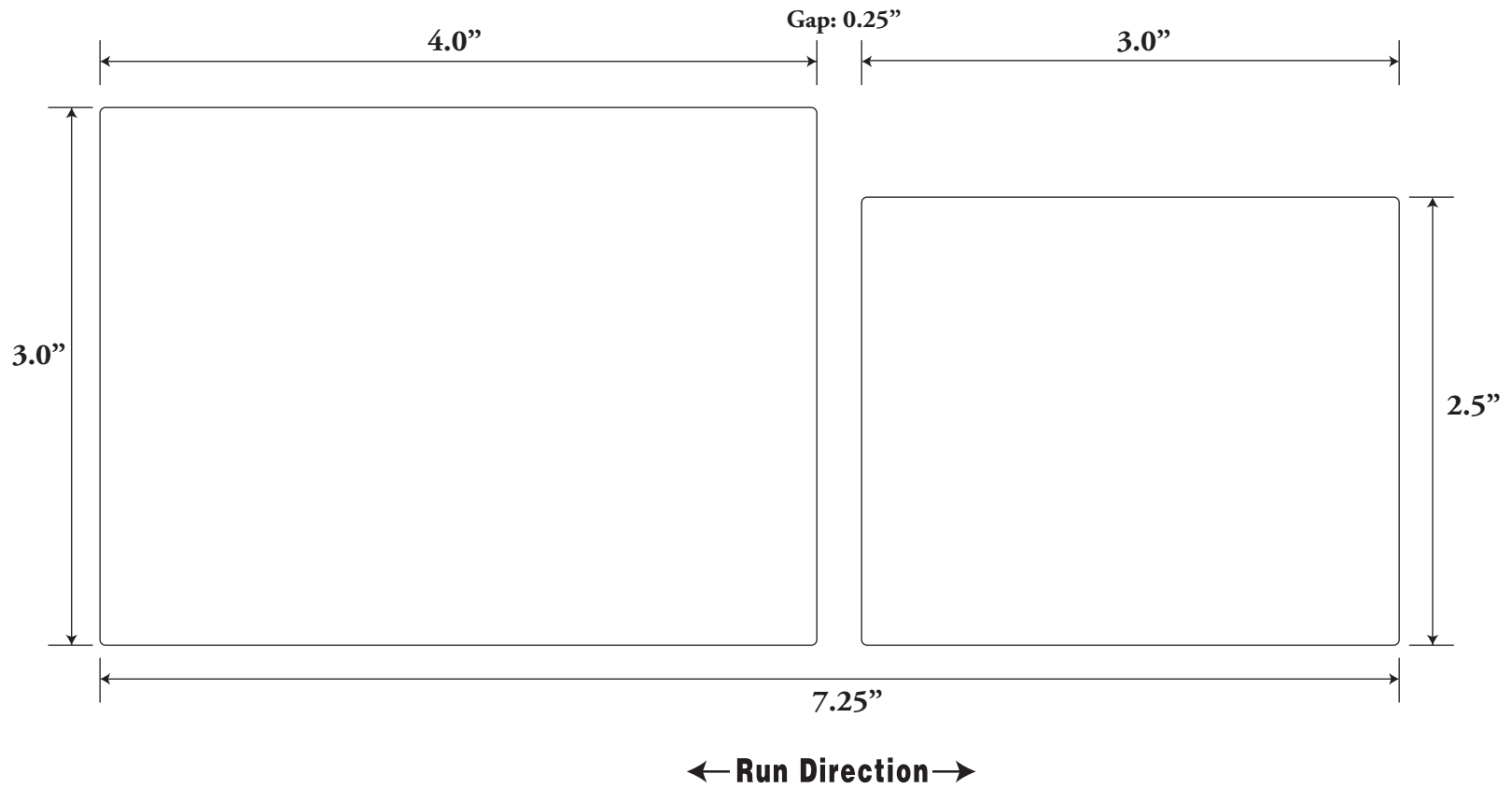

**DIE#** V-259

**SIZE:** 3.5" X 6.46875"

**CORNERS:** 0.078125" (5/64")

**MATERIAL TYPE:** Primax

**VARNISH:** Satin UV

**LAMINATE:** none

**SPECIAL TOOLING:** none

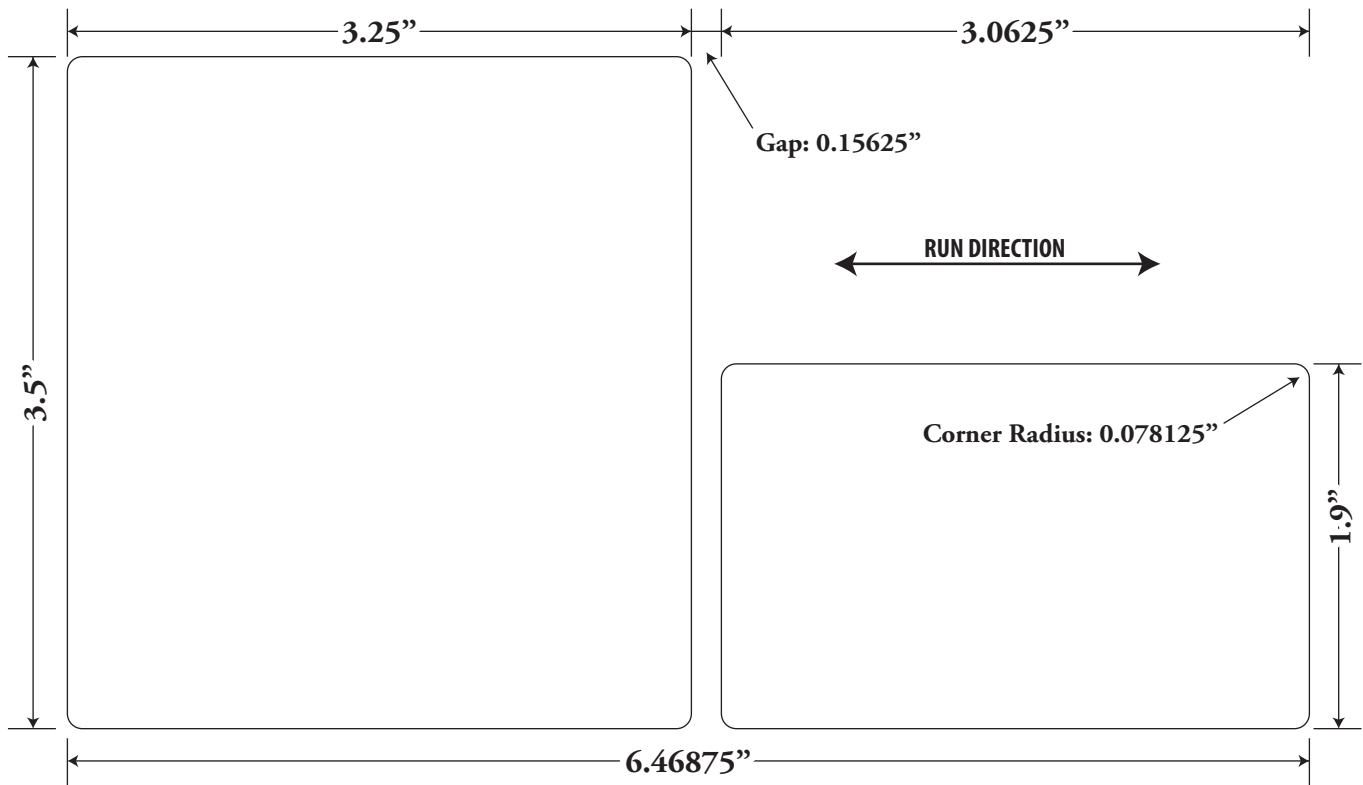

**Die#/Size:** V-262: 4.25" X 4.5"  
**Corners:** .015625  
**Material Type:** Matte Litho  
**Varnish/Laminate:** Crystal Barrier

E

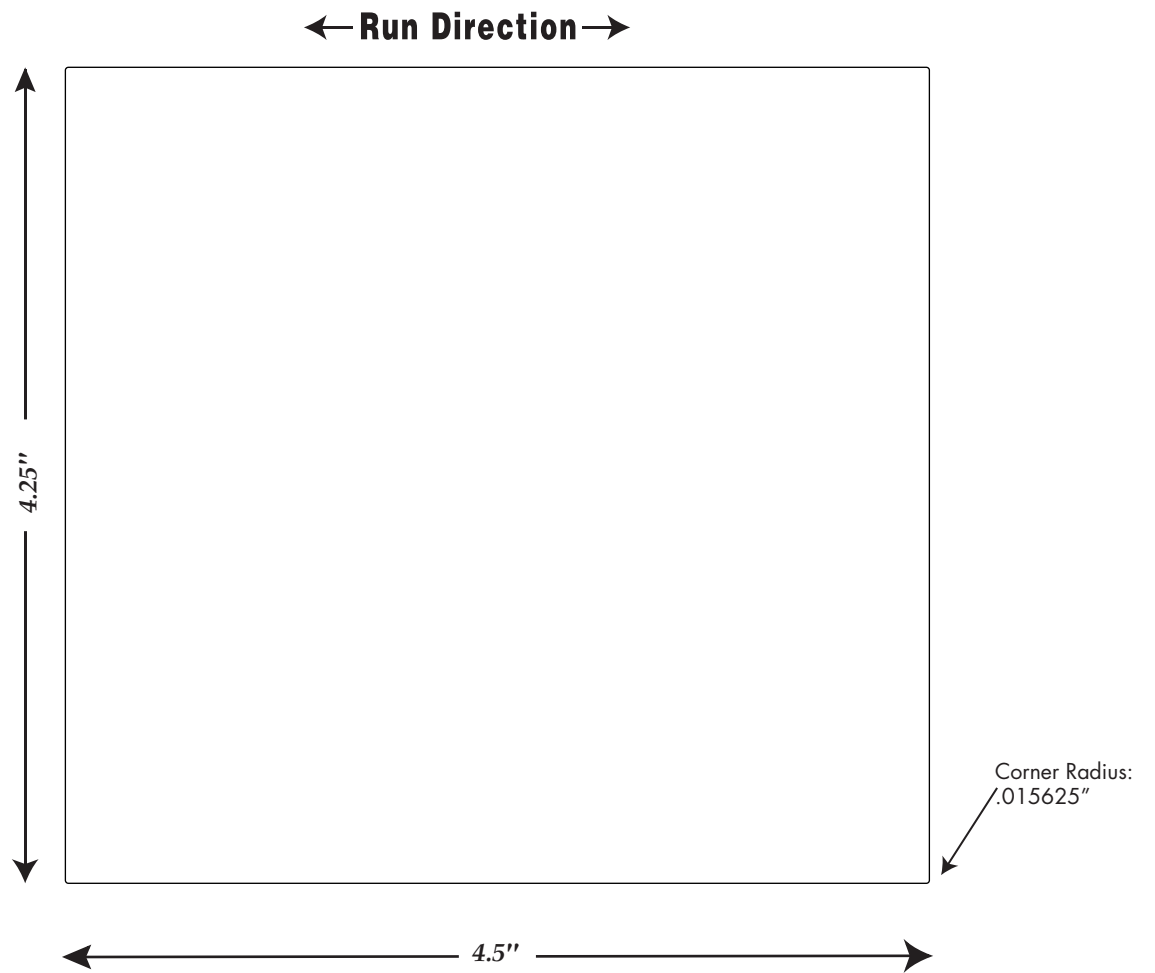

**Die#/Size:** V-264 3.1" x 9.5"  
**Corners:** .0156"  
**Material Type:** Classic Felt  
**Varnish:** Spot UV  
**Laminate:** Matte Crystal Barrier  
**Special tooling:** none

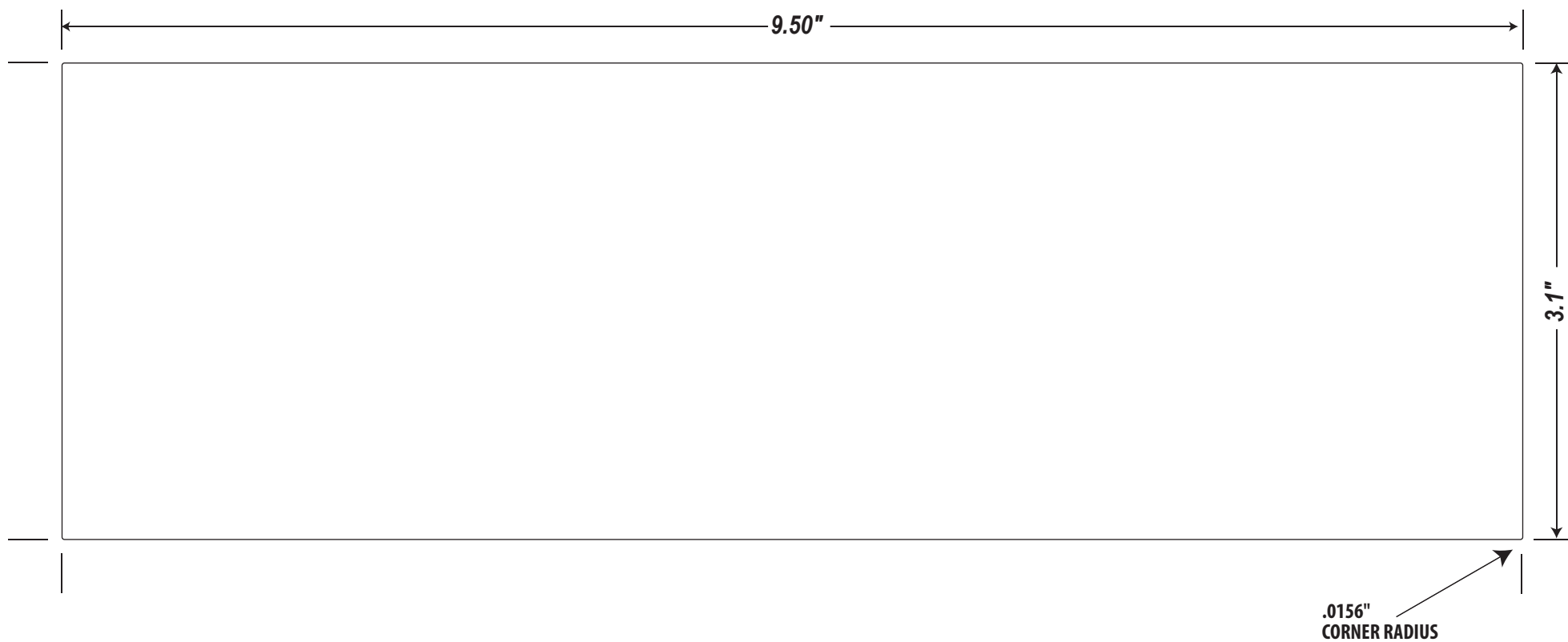

**Die#/Size:** V-265 3.25 x 5.375

**Corners:** .015625

**Material Type:** Eggshell Felt

**Varnish:** yes

**Laminate:** no

**Special tooling:** NEW DIE

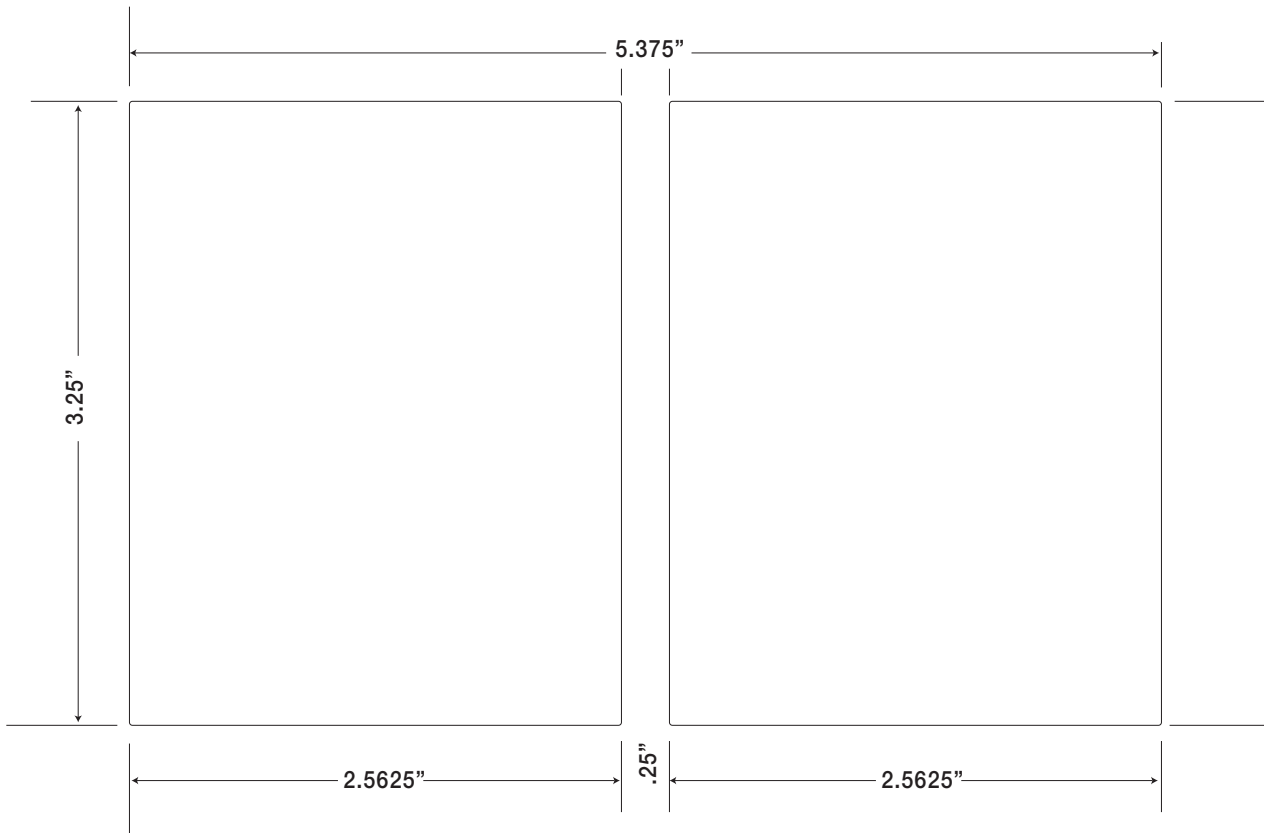

**Die#/Size:** V-266: 3.4399" X 7.4863"  
**Corners:** 1/64"  
**Material Type:** Classic Felt  
**Varnish:** Satin Coat  
**Laminate:** None  
**Shape:** Special

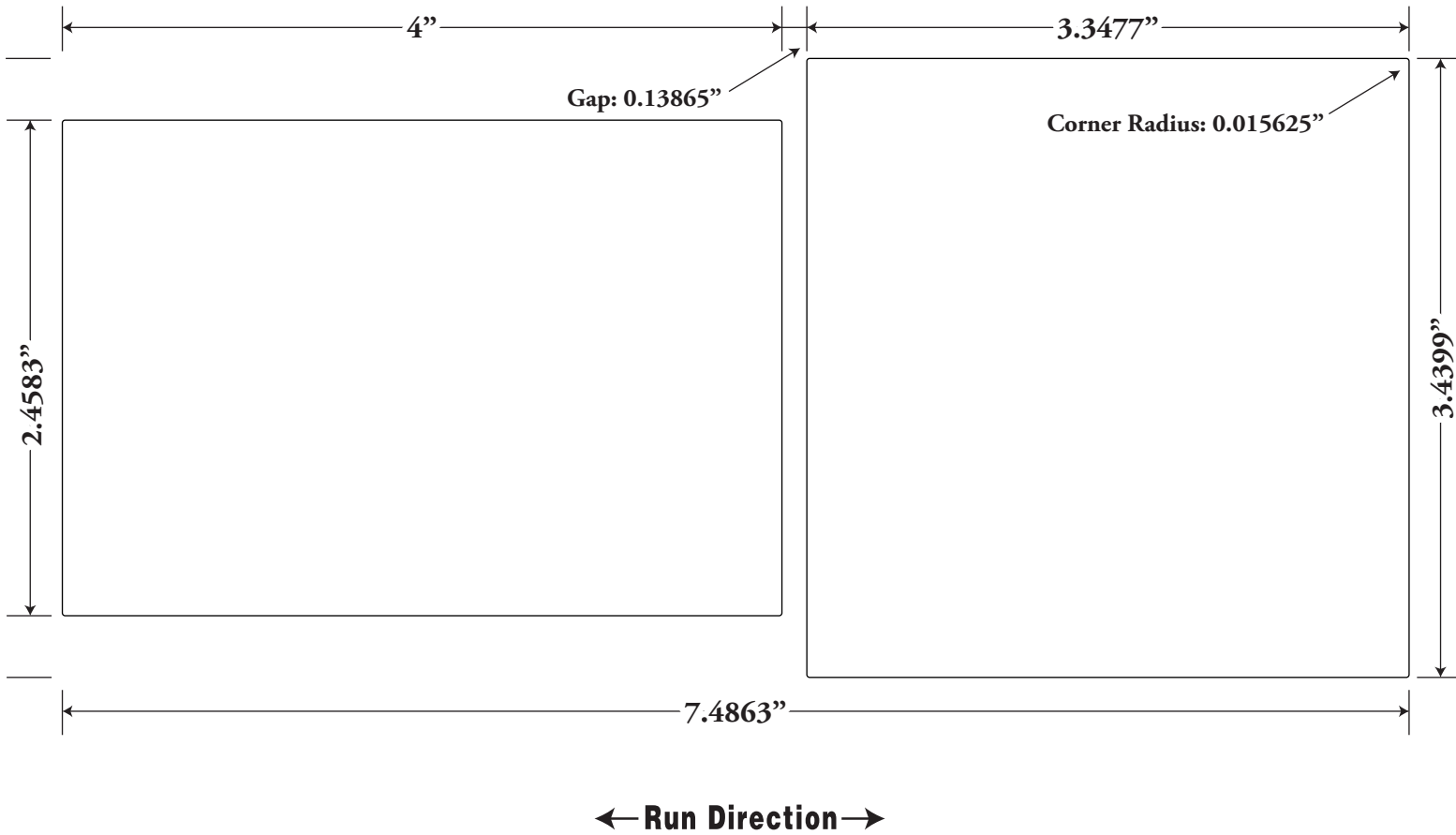

Die#: V-284  
Size: 3.5" x 7.875"  
Corners: 1/64"  
Material Type: Gloss  
Varnish: Scuff Resistent  
Laminate: none  
Special tooling: none

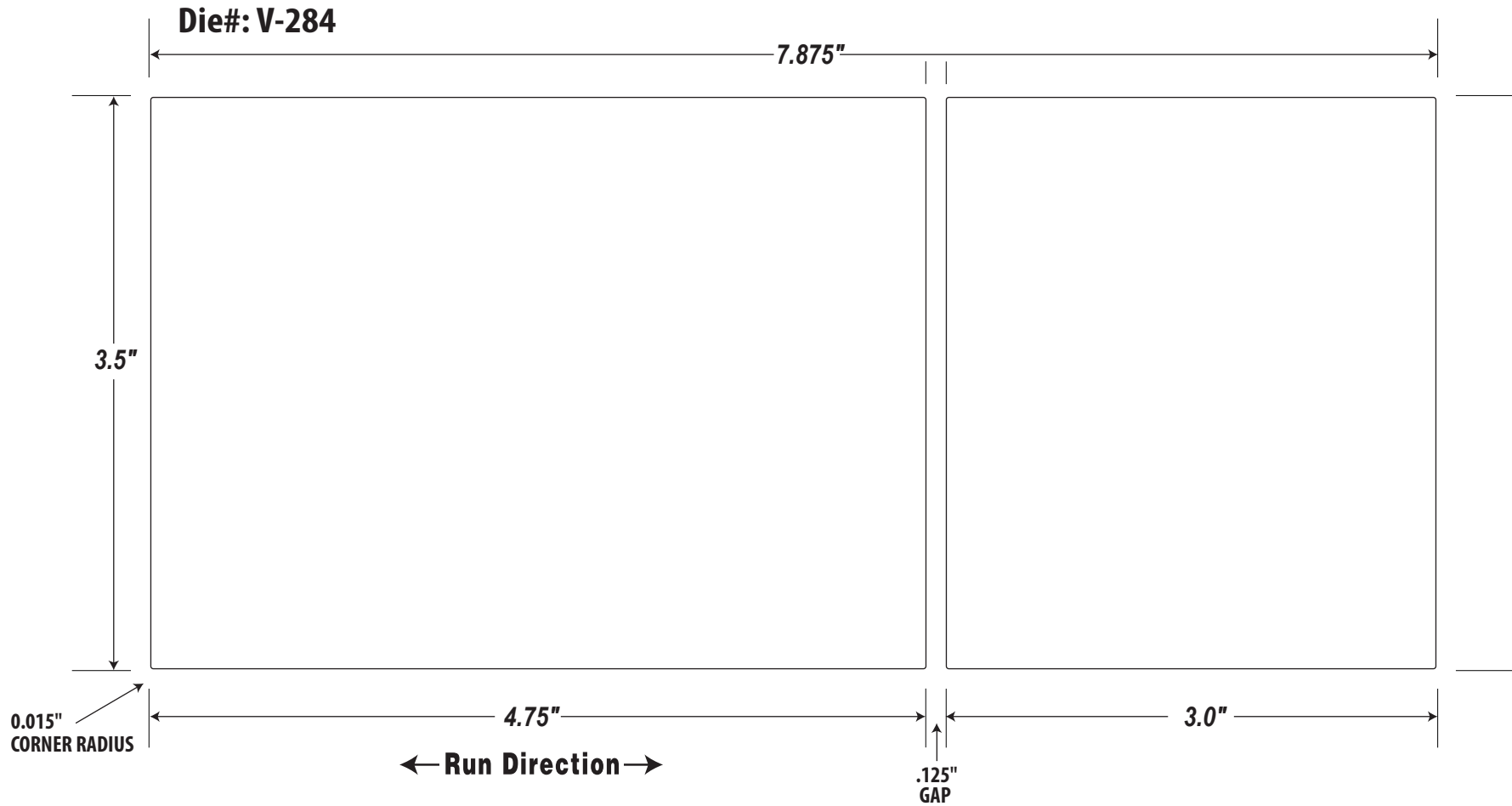

Die#: V-285  
Size: 4.0" x 6.75"  
Corners: 1/64"  
Material Type: Matte Litho  
Varnish: Matte Crystal  
Laminate: none  
Special tooling: none



**Die#/Size:** V-293 3.6125" X 5.625"  
**Corners:** 1/64"  
**Material Type:** Classic Linen  
**Varnish:** Satin 2  
**Laminate:** None

